

**CREATING
POWER
SOLUTIONS**

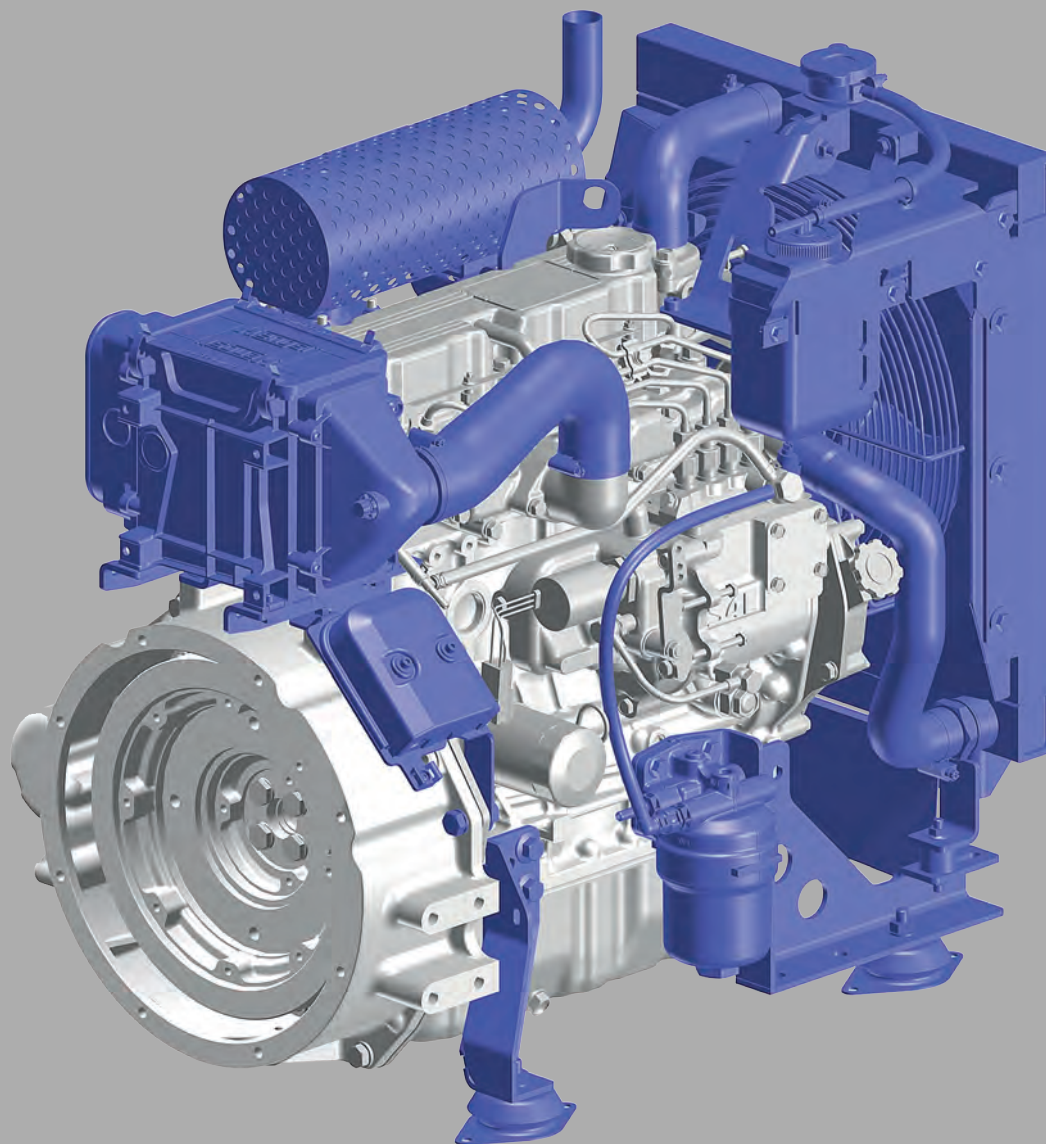

3F30, 3F35E, 3F45, 3F45E, 4F45, 4F45E

INSTALLATION, COMMISSIONING, OPERATION AND MAINTENANCE

Hatz

www.hatz.com

1	Legal notices	5
2	General information	6
3	Safety	7
3.1	General information	7
3.1.1	Intended use	7
3.1.2	Machine user or machine manufacturer obligations	7
3.1.3	Representation of safety notes	8
3.1.4	Meaning of safety symbols	9
3.2	Safety notes	10
3.2.1	Operational safety	10
3.2.2	Machine-specific safety instructions for operation	12
3.2.3	Machine-specific safety instructions for maintenance work	13
3.2.4	Electrical equipment	14
4	Technical data	16
4.1	Engine information and filling quantities	16
4.2	Engine type plate	16
4.3	Engine oil	17
4.4	Coolant	17
4.5	Fuel	19
5	Engine overview	20
5.1	Designation of components	20
6	Transport	22
6.1	Transport	22
7	Installation	24
7.1	Installation notes	24
7.1.1	Torques and screw classification	24
7.2	Engine suspension	24
7.2.1	Engine brackets	25
7.2.2	Flexible engine mounting - Vibration damper	25
7.2.3	Rigid engine suspension	28
7.2.4	Uniform bearing load	29
7.3	Engine cooling	30
7.3.1	Installation of the cooler under a cover	30
7.3.2	Amount of heat to be dissipated at the full load curve (100 % engine load)	31
7.4	Fuel system	36
7.4.1	Fuel circuit diagram - installation of fuel lines	36
7.4.2	Electric fuel pump	37
7.4.3	Fuel main filter	38
7.4.4	Fuel tank	39
7.5	Exhaust system	41
7.5.1	Dimensioning of the exhaust gas system	41
7.6	Intake and combustion air	44
7.6.1	Intake section	47
7.7	Engine oil	48
7.8	Electrical system	49
7.8.1	Cabling	49
7.8.2	Engine monitoring	52
7.8.3	Retaining plate for relay	53
7.8.4	Battery	53
7.8.5	Battery recommendation	55
7.8.6	Battery compartment	55
7.8.7	Starter	56
7.8.8	Alternator	57
7.9	Power take off	59

7.9.1	Main take off – flywheel side	59
7.9.2	Main power take off – timing cover side (belt drive)	59
7.9.3	Torsion momentum calculation	60
7.9.4	7.5" flywheel with connection housing SAE5	61
7.9.5	Flywheel 6.5" with connection housing SAE5	63
7.10	General limits of use	64
7.10.1	Cold start capability	64
7.10.2	Extreme conditions	64
7.11	Maintenance	64
7.11.1	Accessibility of service points	64
7.12	Contact protection for machine safety	65
7.12.1	Contact guard	65
7.12.2	Hot surfaces and rotating parts	66
8	Commissioning	68
8.1	Preparations for commissioning	68
8.2	Filling engine oil (first filling)	68
8.3	Filling the cooling system	69
8.4	Venting the fuel system	70
9	Operation and use	72
9.1	Safety notes	72
9.2	Performing tests	72
9.3	Starting the engine	73
9.4	Switching off the engine	75
9.5	Checking the oil level	76
9.6	Refueling	78
10	Maintenance	79
10.1	General maintenance instructions	79
10.2	Maintenance work	80
10.2.1	Maintenance plan	80
10.2.2	Checking the intake area of the combustion air	81
10.2.3	Checking the cooler fins for dirt accumulation	82
10.2.4	Checking the cooling system	83
10.2.5	Change the engine oil and oil filter	86
10.2.6	Cleaning the radiator fins	89
10.2.7	Checking the belt and belt tension	90
10.2.8	Changing the belt	93
10.2.9	Checking the screw connections	94
10.2.10	Draining the water separator	94
10.2.11	Changing the fuel prefilter	95
10.2.12	Changing the main fuel filter	97
10.2.13	Air filter maintenance	99
10.2.14	Changing the coolant	102
11	Faults	105
11.1	Troubleshooting	105
12	Storing the machine	107
13	Change history	109

1 Legal notices

Contact data

© 2025
 Motorenfabrik Hatz
 Ernst-Hatz-Straße 16
 94099 Ruhstorf
 Germany
 Tel. +49 (0)8531 319-0
 Fax +49 (0)8531 319-418
 marketing@hatz.com
 www.hatz.com
 All rights reserved!

Copyright

The copyright for this manual rests entirely with Motorenfabrik HATZ, Ruhstorf.

This manual may only be copied or distributed if written approval has been received. This also applies to the copying or distribution of excerpts of this manual. The same conditions apply to distribution of this manual to third parties in digital form.

Original manual

This manual has been translated into multiple languages.

The German version is the **original manual**. All other language versions are **translations** of the **original manual**.

Revision

Version	Date	Name
Ver. 00	12.09.2024	GMT-CI / ef, bw
Ver. 01	28.01.2025	GMT-CI / ef, bw
Ver. 02	19.03.2025	GMT-CI / ef, bw
Ver. 03	23.06.2025	GMT-CI / ef, bw

For details on the individual versions, see section 13 *Change history*, page 109.

2 General information

Information on the document

This manual was created with due care. It is exclusively intended to offer a technical description of the machine and to provide instructions on installation, commissioning, operation and maintenance of the machine. When installing and operating the machine, the applicable standards and legal regulations as well as any in-house regulations apply.

Before commissioning, during operation and before maintenance work is begun on the machine, read this manual carefully and keep it close by for ready access.

Machine

This manual describes the following machine.

Machine name	Hatz diesel engine
Type number	3F30, 3F35E, 3F45, 3F45E, 4F45, 4F45E

Customer service

Have service work performed by qualified technicians only. We recommend that you work with one of the over 500 **HATZ service stations**. Your machine will be repaired there by personnel with up-to-date training using **genuine spare parts**. The global HATZ service network is at your disposal to advise you and supply you with spare parts. For your nearest **Hatz service center**, please see **www.hatz.com** on the internet.

Installation of unsuitable spare parts can lead to problems. We cannot accept liability for direct damage or secondary damage that results from this.

We therefore recommend the use of **genuine spare parts**. These parts are manufactured according to strict manufacturer specifications and achieve maximum operational reliability through their perfect fit and functionality. The order number can be found in the enclosed spare parts list or on the internet at: **www.hatz.com**

Exclusion of liability

The manufacturer cannot be held liable for personal injury, damage to property or damage to the machine itself caused by improper use, foreseeable misuse, or failure to follow or adequately follow the safety measures and procedures described in this manual. This also applies to changes made to the machine and the use of unsuitable spare parts.

Modifications, which serve the technical improvements, are reserved.

3 Safety

3.1 General information

3.1.1 Intended use

Intended use

The machine described in this manual fulfills the following functions:

- Diesel engine intended for installation in a machine or for assembly with other machines to form a machine.

This engine is intended exclusively for the purpose specified and tested by the manufacturer of the machine in which the engine is installed.

Any other use is not intended and therefore not permitted. Violations compromise the safety of the personnel working with the machine. Motorenfabrik HATZ does not accept any liability for damage resulting from this.

The operational safety of the machine is only guaranteed if it is used as intended.

Use according to the intended purpose also includes observance of the instructions in this Operator's Manual

Foreseeable misuse

The following is considered to be foreseeable misuse:

- Any use that varies from or extends beyond the uses specified above.
- Failure to comply with the instructions in the manual and the applicable documents (see the list of additional documentation in the appendix).
- Failure to comply with the safety instructions.
- Failure to immediately eliminate malfunctions that impact safety before continuing work with the machine (working with the machine when it is not in perfect condition, either functionally or in terms of safety).
- Failure to perform the necessary inspection and maintenance work.
- Any unauthorized modification of or removal of safety equipment.
- Use of spare parts and accessories that are unsuitable or have not been approved by HATZ.
- Fuel other than specified in the instructions.
- Operation in flammable or hazardous environments.
- Operation in closed-off or poorly ventilated rooms.
- Operation in an aggressive atmosphere (e.g., high salt content) without further measures for corrosion protection.
- Improper operation at variance with ISO 3046-1 and ISO 8528 (climate, load, safety).

Residual risks

Residual risks result during daily use and in association with maintenance work.

These residual risks will be pointed out in chapter 3.2.2 *Machine-specific safety instructions for operation, page 12* and in chapter 3.2.3 *Machine-specific safety instructions for maintenance work, page 13* as well as in the further contents of the manual, directly in front of the descriptions or operating instructions concerned.

3.1.2 Machine user or machine manufacturer obligations

Machine manufacturer obligations

These assembly instructions contain important information on how to safely assemble the engine including the equipment delivered by HATZ.

It is prohibited to start the engine before it is fully installed.

It is prohibited to start up the machine before it has been ensured that the machine meets all safety-related measures and legal regulations.

Before placing the machine on the market, the device manufacturer is responsible for ensuring that all legal regulations and the locally applicable requirements for the machine have been fulfilled.

User obligations

The operator is obliged to only operate the machine when it is in perfect condition. The operator must check the condition of the machine before use and ensure that any defects are eliminated before it is taken into service. Operating the machine while identified defects exist is not permitted. The operator must also ensure that all persons who work on the machine are familiar with the contents of this manual, .

Obligations of the operating and maintenance personnel

Personnel assigned with operating and maintaining the machine must have read and understood this manual or must possess the qualifications necessary for working with this equipment, acquired in training/instructional courses. No one may work with the machine without the necessary qualifications, even if for just a brief period.

The operating and maintenance personnel must not be under the influence of drugs, medication or alcohol.

All work performed on the machine must be in compliance with the information provided in this manual.

Storing the Operator's Manual

These instruction and the associated documents are an integral part of this machine (including when sold). They must be stored in the direct vicinity of the machine and be accessible to personnel at all times.

Other applicable documents

For more information on the individual components, see also the detailed information in the respective manufacturer documentation.

The manufacturer documentation is included as an appendix to this Operator's Manual (see the list of additional documentation in the appendix).

3.1.3 Representation of safety notes

Overview

This machine has been designed and built according to state-of-the-art technology and the recognized safety standards. Despite these precautions, risks exist when operating the machine and during maintenance work.

These risks are identified in this manual by means of safety notes.

The safety notes precede the relevant description or operating step.

Structure of the safety notes

The safety notes consist of:

- Danger symbol
- Signal word
- Description of the danger
- Possible consequences
- Preventative measures



General danger symbol



The general danger symbol is used to identify the danger of personal injury.

Signal words









Signal words identify the magnitude of the risk and the seriousness of possible injury:





Danger symbol/ signal word	Meaning
 DANGER	This signal word is used to indicate imminently dangerous situations which, if not avoided, will lead to serious injury or death.
 WARNING	This signal word is used to indicate potentially dangerous situations which, if not avoided, may lead to serious injury or death.
 CAUTION	This signal word is used to indicate potentially dangerous situations which, if not avoided, may lead to minor or moderate injury.
CAUTION	This signal word, without a danger symbol, is used to indicate the risk of property damage.
NOTICE	This signal word indicates additional useful information, such as operating tips and cross references.

3.1.4 Meaning of safety symbols

Explanation of symbols

The following table describes the meanings of the safety symbols used in this manual.

Symbol	Meaning
	Smoking, fire, and open flames are prohibited!
	Warning of personal injury!
	Warning of hot surfaces!
	Warning of hot surfaces! (Alternative)
	Warning of flammable substances!
	Warning of explosive substances!
	Warning of toxic engine exhaust!
	Warning of corrosive substances!



Symbol	Meaning
	Warning of heavy loads!
	Warning of environmental damage!
	Comply with this manual or additional documentation from other manufacturers or the operator.
	Additional information that is useful to the reader.

3.2 Safety notes

3.2.1 Operational safety

Introduction

This chapter contains all of the important safety instructions for personal protection and for safe and reliable operation. Additional, task-related safety instructions can be found at the beginning of each chapter.

 DANGER	
	<p>Danger to life, danger of injury or danger of property damage due to failure to comply with this manual and the safety instructions contained therein.</p> <ul style="list-style-type: none"> ▪ As the operator of the machine, you must ensure that all people working on the machine are familiar with the content of this manual. ▪ Before working on the machine, read this manual carefully, paying special attention to the safety notes in .. ▪ Fulfill all required safety conditions before working on the machine. ▪ Follow all general safety instructions as well as the specific task-related safety instructions contained in the individual chapters.

Using the machine







- Only operate the machine for the purposes described in chapter 3.1.1 *Intended use, page 7*.

Compliance with other regulations

- The applicable regulations of the relevant professional associations must be observed.
- Comply with the regulations concerning the minimum safety and health requirements for the use of work equipment by workers at work.
- In addition, local safety, accident prevention and environmental regulations also apply when operating the machine.

Personal protective equipment

During operation and maintenance of the machine, personal protective equipment must be available and must be used if necessary. The use of personal protective equipment is specified in the description of the operating steps.

Personal protective equipment	Pictogram	Function
Safety shoes		Safety shoes offer protection against: <ul style="list-style-type: none"> ▪ Slipping ▪ Falling objects
Hearing protection		Hearing protection offers protection against ear injuries due to excessive and constant noise.
Safety gloves		Safety gloves protect the hands against injury, e.g., from battery acid.
Safety goggles (with side protection)		Safety goggles protect the eyes from flying objects (e.g., dust particles, spraying liquids, spraying acid).
Fine dust mask		A fine dust mask protects the wearer against particulate pollutants.
Working clothes		Wear close-fitting working clothes. It must not restrict the wearer's freedom of movement, however.

Warning labels and information signs on the machine

The warning labels and information signs on the machine must be followed.

The warning labels and information signs must be kept legible and must be replaced if necessary. For this purpose, contact your nearest **HATZ service station**.

Maintenance work



Maintenance work that goes beyond the scope described in this manual must only be performed by qualified technicians (see chapter 2 *General information*, page 6).







Independent maintenance work and constructional changes to the machine, especially to the safety equipment, are not permitted.

Safety equipment

Safety equipment must not be modified and must not be rendered ineffective during normal operation.

General safety instructions

 DANGER	
	<p>Danger to life and danger of injury due to failure to follow the warnings on the machine and in this manual.</p> <ul style="list-style-type: none"> ▪ Heed the warnings on the machine and in this manual.

 WARNING	
	<p>Danger of injury and danger of incorrect operation due to inadequate personnel qualifications.</p> <ul style="list-style-type: none"> ▪ The personnel must have read and understood this manual or must possess the qualifications necessary for working with this equipment, acquired in training/instructional courses. ▪ Only qualified personnel is permitted to operate and maintain this machine. ▪ Failure to comply will cause the warranty to become void.
 WARNING	
	<p>Danger of injury from failure to follow the Operating Instructions and from performing unauthorized tasks on the machine.</p> <ul style="list-style-type: none"> ▪ Follow all instructions. ▪ Do not perform activities for which no qualification is available. Contact properly trained personnel if necessary.
 CAUTION	
	<p>Danger of injury from overloading the body.</p> <p>Lifting the machine to transport it or to move it to another location can lead to injuries (of the back, for example)</p> <ul style="list-style-type: none"> ▪ Only lift the machine with a hoist (see chapter 6.1 <i>Transport</i>, page 22).

3.2.2 Machine-specific safety instructions for operation

Introduction

The machine can pose residual risks during operation. To eliminate these risks, all persons working on the machine must follow the general and machine-specific safety instructions.

If you have an engine that is not yet installed in a machine, it is imperative that you follow these instructions before installing the engine .

These Instructions contain important information on safe installation.

If the engine is installed in a machine or assembled with other machines to form a machine, it is prohibited to start the engine before it has been determined that the newly created machine fulfills all safety-related requirements and applicable legal regulations.







Safe operation

- Before switching on the machine, ensure that no one can be injured when the machine is started up.
- During machine operation, ensure that unauthorized persons do not have access to the area in which the machine has an impact.
- Parts of the exhaust gas system and the surface of the engine become hot during operation. Risk of injury from touching hot parts! Let the engine cool before maintenance.
- Do not refuel during operation if this would result in a potential danger, e.g., if the engine would be operated close to the tank.

Faults

- Immediately eliminate faults that compromise safety.
- Switch off the machine and do not take into service again until all faults have been eliminated.

Safety instructions for operation

 DANGER	
	<p>Danger to life from inhaling exhaust gases.</p> <p>Toxic engine exhaust gases can lead to loss of consciousness, and even death, in closed-off and poorly ventilated rooms.</p> <ul style="list-style-type: none"> ▪ Never operate the machine in closed-off or poorly ventilated rooms. ▪ Do not breathe in the exhaust gases.
 DANGER	
 	<p>Fire hazard from fuel.</p> <p>Leaked or spilled fuel can ignite on hot engine parts and cause serious burn injuries.</p> <ul style="list-style-type: none"> ▪ Only refuel when the engine is switched off and has cooled down. ▪ Never refuel in the vicinity of open flames or sparks that can cause ignition. ▪ Do not smoke. ▪ Do not spill fuel.
 DANGER	
	<p>Danger of fire from hot exhaust gas system.</p> <p>If inflammable materials come into contact with the exhaust gas flow or the hot exhaust gas system, these materials can ignite.</p> <ul style="list-style-type: none"> ▪ Keep inflammable materials away from the exhaust gas system. ▪ Do not operate the engine (exhaust flow or hot exhaust gas system) in the direct vicinity of combustible materials.

3.2.3 Machine-specific safety instructions for maintenance work

Introduction

The machine can pose residual risks during maintenance. To eliminate these risks, all persons working on the machine must follow the general and machine-specific safety instructions.

Maintenance intervals

- Strictly adhere to the maintenance intervals.
- Check the safety equipment regularly to ensure it is in good condition and functioning properly.
- Check connections, cables and fasteners regularly to ensure they are in good condition.

Maintenance work

Maintenance work that goes beyond the scope described in this manual must only be performed by qualified technicians. We recommend that you work with one of the over 500 **HATZ service stations**.









Replacing parts

- When replacing defective components, we recommend that you use **genuine Hatz spare parts** (see chapter 2 *General information*, page 6).
- When disposing of parts that can no longer be used, do so in accordance with local environmental regulations or send them to a recycling center.

Measures following maintenance and troubleshooting





- Securely reconnect loose electrical connections; check that the electrical components and equipment are functioning properly.
- Check the entire machine for foreign bodies; remove any foreign bodies.



Safety instructions for maintenance work

 DANGER	
	<p>Danger of explosion from flammable cleaning agents.</p> <p>Cleaning with benzene is an explosion hazard. It is highly flammable, can become electrostatically charged, and can generate an explosive gas/air mixture.</p> <ul style="list-style-type: none"> ▪ Use halogen-free, cold cleaners with a high flash point for cleaning. ▪ Comply with manufacturer's instructions.
 WARNING	
 	<p>Danger of injury from compressed air and dust particles.</p> <p>Eye injuries can occur when cleaning with compressed air.</p> <ul style="list-style-type: none"> ▪ Wear safety goggles.
 CAUTION	
	<p>Danger of injury from ignoring the maintenance instructions.</p> <ul style="list-style-type: none"> ▪ Only perform maintenance work when the engine is switched off. ▪ For engines with an electric starter: Disconnect the negative battery terminal. Protect the starting key from unauthorized access.
 CAUTION	
	<p>Danger of burns.</p> <p>There is a danger of burns when working on a hot engine.</p> <ul style="list-style-type: none"> ▪ Let the engine cool before maintenance.

3.2.4 Electrical equipment

Safety notes

 DANGER	
	<p>Danger to life, danger of injury or danger of property damage due to incorrect use of batteries.</p> <ul style="list-style-type: none"> ▪ Do not place tools or other metal objects on the battery. ▪ Before performing work on the electrical equipment, always disconnect the negative battery terminal. ▪ Never swap the positive (+) and negative (–) battery terminals. ▪ When installing the battery, first connect the positive cable and then the negative cable. ▪ When removing the battery, first disconnect the negative cable and then the positive cable. ▪ It is imperative to prevent short circuits and mass contact of current carrying cables. ▪ If faults occur, check the cable connections for good contact.
 DANGER	
	<p>Danger of explosion from flammable substances.</p> <p>There is a danger of explosion from flammable gases.</p> <ul style="list-style-type: none"> ▪ Keep batteries away from open flames and incendiary sparks. ▪ Do not smoke when working with batteries.

 CAUTION	
	<p>Danger of chemical burns</p> <p>Chemical burns can occur when using batteries for the electrical operation.</p> <ul style="list-style-type: none">▪ Protect your eyes, skin, and clothing from corrosive battery acid.▪ Immediately rinse areas affected by splashed acid with clear water and consult a physician if necessary.

- Promptly replace faulty indicator lamps.
- Do not disconnect the battery while the machine is running. Resulting voltage peaks could destroy the electronic components.
- When cleaning, do not spray the electrical equipment components with a water jet or high pressure cleaner.
- When performing welding work on the machine, disconnect the battery and place the ground clamp of the welding equipment as close as possible to the welding area. Disconnect the plug-in connections to the voltage regulator.

NOTICE	
	<ul style="list-style-type: none">▪ We cannot be held liable for electrical equipment that is not designed according to HATZ wiring diagrams.

4 Technical data

4.1 Engine information and filling quantities

Type		3F30	3F35E	3F45 3F45E	4F45 4F45E
Mechanical speed control					
Electronic speed control					
Type		Liquid-cooled four stroke diesel engine			
Combustion system		Swirl chamber			
Number of cylinders		3	3	3	4
Bore/Stroke	mm	76 / 70	76 / 81	78 / 92	78 / 92
Displacement	cm ³	952	1102	1318	1758
Engine oil capacity	Approx. ltr.	3.6 ¹⁾	4,5 ¹⁾	4.2 ¹⁾	6.0 ¹⁾
Difference between "max" and "min" marking	Approx. ltr.	1.3 ¹⁾	1.1 ¹⁾	1.3 ¹⁾	1.8 ¹⁾
Engine oil consumption (after running-in period) based on full load	Approx.	0.1–0.3% of fuel consumption at rated speed			
Engine oil pressure at oil temperature of max. 90 °C and low idle speed	approx. bar	0.8	1.0	1.0	1.0
Max. permissible engine oil temperature		115 °C			
Sense of rotation		Left (view toward flywheel)			
Coolant filling quantity (engine)	Approx. ltr.	1.8	1.8	1.8	2.5
Coolant filling quantity (engine with Hatz cooler)	Approx. ltr.	4.2	4.2	4.2	4.9
Max. permissible coolant temperature at engine outlet		105 °C			
Dry weight					
Basic engine	Approx. kg	107	110	153	163
Open Power Unit (OPU)	Approx. kg	141	141	186	197

¹⁾ These specifications are approximate values. The max. mark on the dipstick is decisive in any case (see section 9.5 *Checking the oil level*, page 76).

4.2 Engine type plate

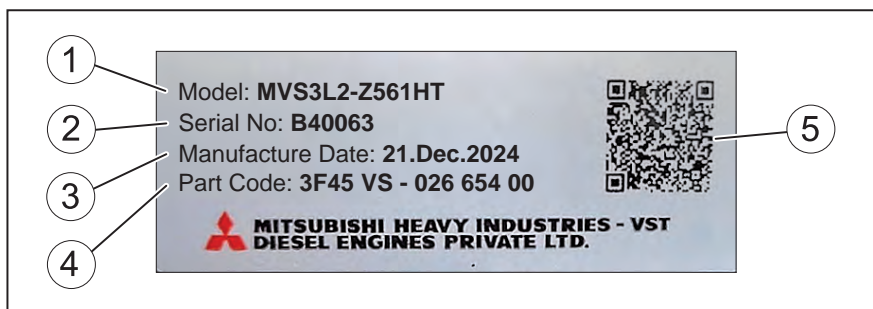

The engine type plate is affixed to the cylinder head cover and includes the following engine information:

1	Model designation of the engine
2	Engine serial number
3	Model year (day/month/year)
4	Hatz part code (type designation and material number)
5	QR code with link to Hatz online documentation

4.3 Engine oil

Oil quality

All brand name oils that satisfy the following specification are suitable:

- API – CF / CH-4 or better

Oil viscosity

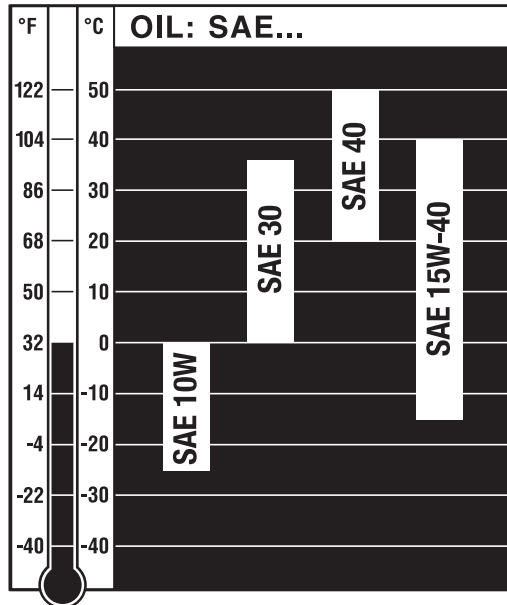

Select the recommended viscosity depending on the ambient temperature at which the engine will be operated.

CAUTION	
	<p>Engine damage from unsuitable engine oil.</p> <p>Unsuitable engine oil considerably reduces engine service life. Only use engine oil that fulfills the specifications stipulated above.</p>



4.4 Coolant



Introduction

Liquid-cooled engines require a coolant specified by the engine manufacturer for engine cooling. Coolant is prepared in accordance with manufacturer's instructions of the product in question; please comply with the information on the packaging label.

Cooler protection fluids give effective protection against corrosion and freezing. In addition, the coolant boiling point is significantly raised and deposits of lime in the cooling system are reduced.

Safety notes

 CAUTION	
	<p>Danger of damage to health</p> <p>Cooler protection fluids are harmful to health.</p> <ul style="list-style-type: none"> ▪ Avoid contact to eyes and skin. ▪ Store only in the sealed original container and in a place inaccessible for unauthorized persons. ▪ Comply with manufacturer's instructions.

 CAUTION	
	<p>Danger of environmental damage from spilled coolant.</p> <p>Coolant is water-polluting.</p> <ul style="list-style-type: none"> Do not allow them to enter the ground water, water bodies, or sewage system. Collect the coolant and dispose of it according to local environmental regulations.
CAUTION	
	<p>Danger of engine damage from cooler protection fluid.</p> <p>Use of a cooler protection fluid not approved by the engine manufacturer can cause engine damage.</p> <ul style="list-style-type: none"> If you have any questions, please contact your nearest HATZ Service before commissioning the engine.

Specification

All long-term cooler protection fluids that meet the specification **JIS K2234** are suitable.

Preparation of the coolant

CAUTION	
	<p>Danger of engine damage from incorrect radiator protection fluid concentration.</p> <p>If the cooler protection fluid concentration is too low, this increases the risk of corrosion as well as the risk of the cooling system freezing. If the cooler protection fluid concentration is too high, this lowers the cooling effect as well as the freezing protection. Therefore, serious engine damage may result from exceeding or dropping below the cooler protection fluid concentration.</p>

- The cooler protection fluid must be prepared according to the manufacturer's instructions before filling into the cooling circuit or some cooler protection fluids are also offered as premixed formulations. Be sure to comply with the information on the packaging label.
- If the cooler protection fluid has to be mixed with water, use only clean, soft water. Drinking water with as low a content of salt, minerals and suspended matter as possible is ideal. Demineralized or distilled water is also ideal.

The following limit values must not be exceeded:

Water quality	Chemical symbol	Unit	Recommended value	Limit value
pH value (25 °C [77 °F])	–	–	6.5 to 8.0	6.5 to 8.0
Electrical conductivity (25 °C [77 °F])	–	mS/m	≤ 25	≤ 40
Total hardness	CaCO ₃	ppm	≤ 95	≤ 100
M alkalinity	CaCO ₃	ppm	≤ 70	≤ 150
Chlorine ions	Cl ⁻	ppm	≤ 100	≤ 100
Sulfuric acid ions	SO ₄ ²⁻	ppm	≤ 50	≤ 100
Total iron	Fe	ppm	≤ 1.0	≤ 1.0
Silicon	SiO ₂	ppm	≤ 30	≤ 50
Residue from evaporation	–	ppm	≤ 250	≤ 400

The coolant mixture ratio must not be below or exceed the following concentration:

Radiator protection fluid	Water	Frost-resistant to approx. *
min. 40 vol%	60 vol%	-24 °C
max. 50 vol%	50 vol%	-36 °C

* These details depend on the product in question. Be sure to comply with the packaging label.

4.5 Fuel

Fuel type

All types of diesel fuel that meet the minimum requirements of the following specifications are suitable:

- **Europe: EN 590**
- **UK: BS 2869 A1/A2**
- **ASTM D 975-09a 1-D or 2-D**
- **Japan: JIS K 2204**

CAUTION

Danger of engine damage from low quality fuel.

The use of fuel that does not meet the specifications can lead to engine damage.

- Only use fuel that is very low in sulfur or that contains no sulfur at all.
- The use of fuels that do not meet specifications require approval by Motorenfabrik HATZ (main plant).

CAUTION

Danger of malfunctions due to old fuel.

When diesel fuel is stored in a fuel tank or canister for lengthy periods, deposits may form on account of fuel aging. These deposits result in malfunctions due to clogged fuel filters and damage to the injection system.

- Perform the prescribed storage steps in machines that will be out of use for more than three months (see chapter *12 Storing the machine, page 107*).
- Only refuel with fresh diesel fuel such as can be obtained from filling stations.

Winter fuel

Diesel fuel loses its fluidity at low temperatures, which can lead to operating problems. Use cold-resistant winter diesel fuel for outside temperatures below 0 °C.

5 Engine overview

5.1 Designation of components

Model – OPU (Open Power Unit)
Intake side

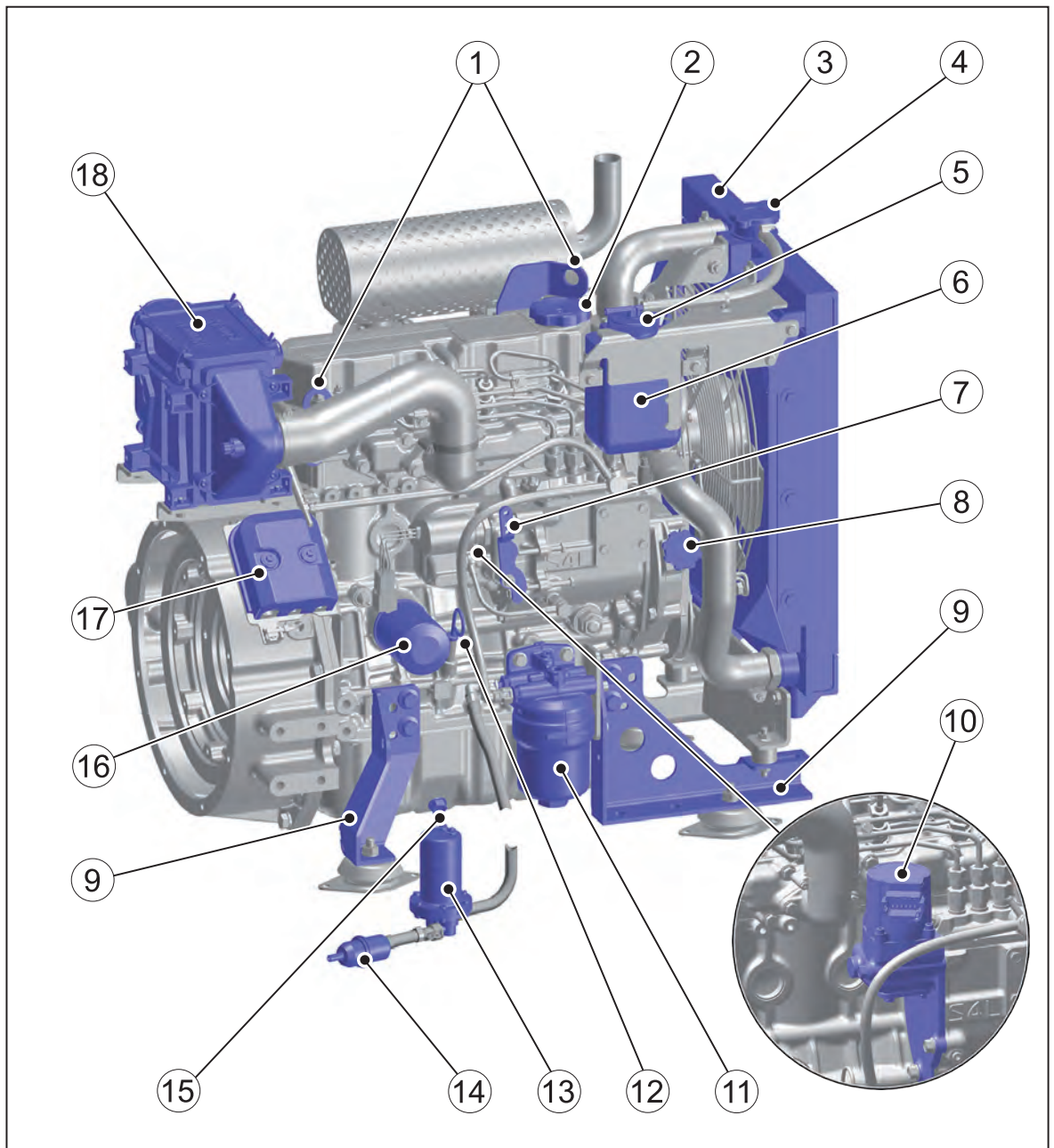

1	Lifting eyes	10	Electronic speed governor (only for 3F35E, 3F45E and 4F45E)
2	Oil filler plug, top	11	Main fuel filter
3	Cooler	12	Dipstick
4	Cooler cap	13	Electric fuel pump
5	Screw plug on the overflow container	14	Fuel prefilter
6	Overflow container	15	Oil drain screw
7	Speed control lever (only for 3F30, 3F45 and 4F45)	16	Oil filter
8	Oil filler plug, bottom	17	Relay cover
9	Engine bracket	18	Air filter

**Model – OPU (Open Power Unit)
Exhaust gas side**

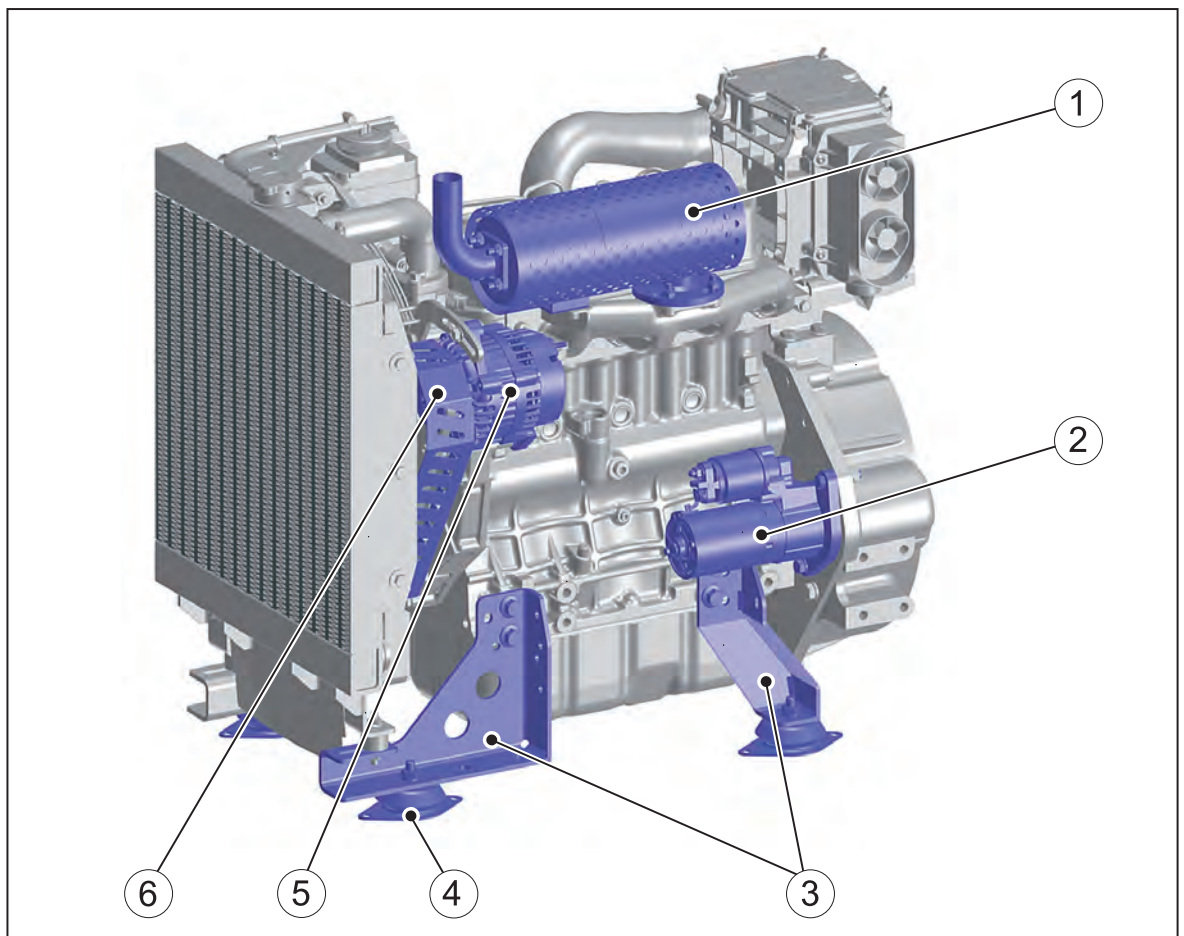

1	Muffler with contact protection	4	Vibration damper
2	Starter	5	Three phase alternator
3	Engine bracket	6	Belt guard

NOTICE









The Open Power Unit (OPU) is a complete system which, in addition to the engine, features all components required for operation, such as the cooling system, fuel system, electrical system, combustion air filter and muffler.

6 Transport

6.1 Transport

Safety notes

 WARNING	
	<p>Danger of injury from improper lifting and transport.</p> <p>Danger of crushing from the engine falling or tipping.</p> <ul style="list-style-type: none"> ▪ The machine may only be lifted using the lifting points (1). ▪ Before lifting the engine, check the lifting eyes for deformation and damage. Lifting with deformed or damaged lifting eyes is not permitted. Replace deformed or damaged lifting eyes before using them for lifting. ▪ Before lifting the engine, ensure that the fixing screws of the lifting eyes are tight. ▪ Only use a suitable hoist with a sufficient carrying capacity. ▪ Always use all lifting eyes for lifting. ▪ Do not remain under suspended loads.
 CAUTION	
	<p>Only use the lifting eye for transporting the engine.</p> <p>Do not use for lifting the entire machine.</p>
 CAUTION	
	<p>Danger of injury from overloading the body.</p> <p>Lifting the machine to transport it or to move it to another location can lead to injuries (of the back, for example).</p> <ul style="list-style-type: none"> ▪ Only lift the machine with a hoist.
NOTICE	
	<p>Danger of environmental damage from leaking fluid.</p> <p>If the machine is tilted, engine oil and fuel can run out.</p> <ul style="list-style-type: none"> ▪ Only transport the machine in an upright position.

Transport conditions

- When transporting the machine, follow the safety instructions.
- When transporting, follow the applicable safety and accident prevention regulations.
- After delivery, check the machine for completeness and transport damage.
- Only transport the machine when it is switched off and has cooled down.
- If you have questions on transporting the machine, please contact your nearest **HATZ service station**. For contact data, see chapter Legal notices or www.hatz-diesel.com.

Lifting points 3F30, 3F35

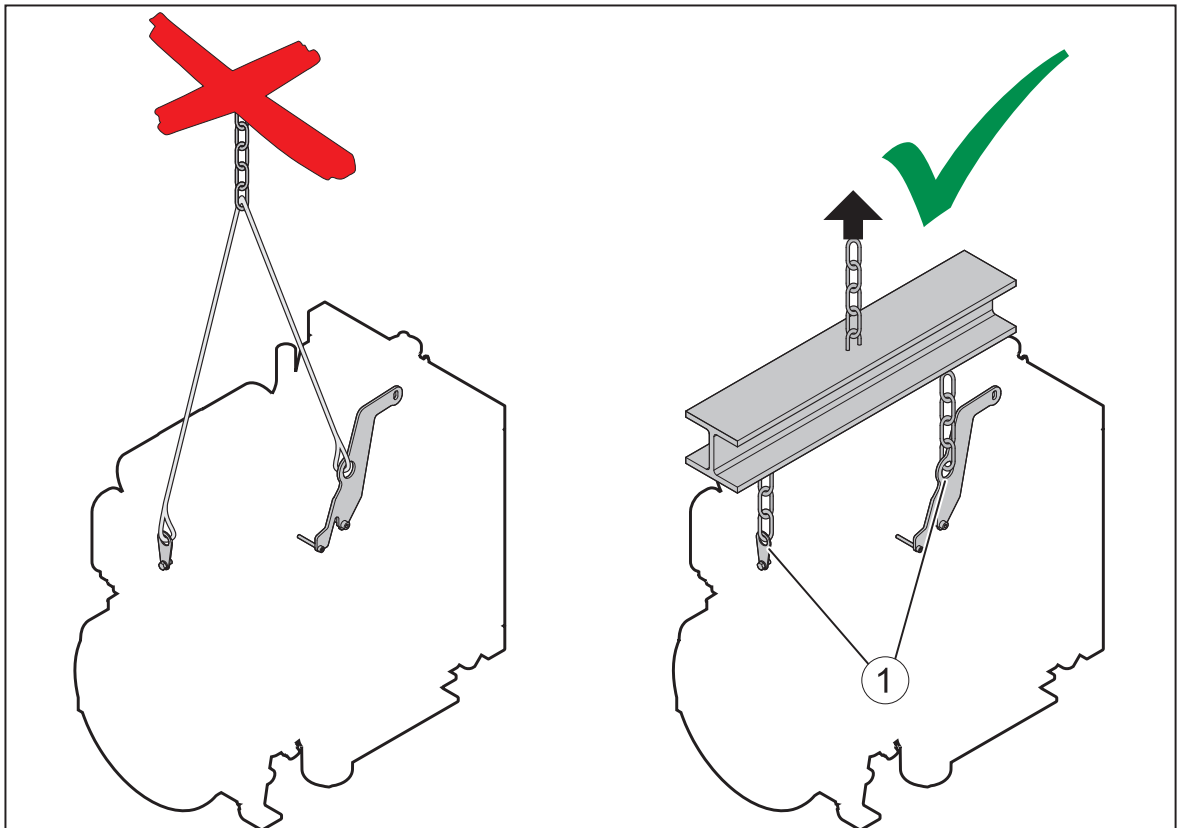

1 | Lifting points

Lifting point 3F45, 3F45E, 4F45, 4F45E

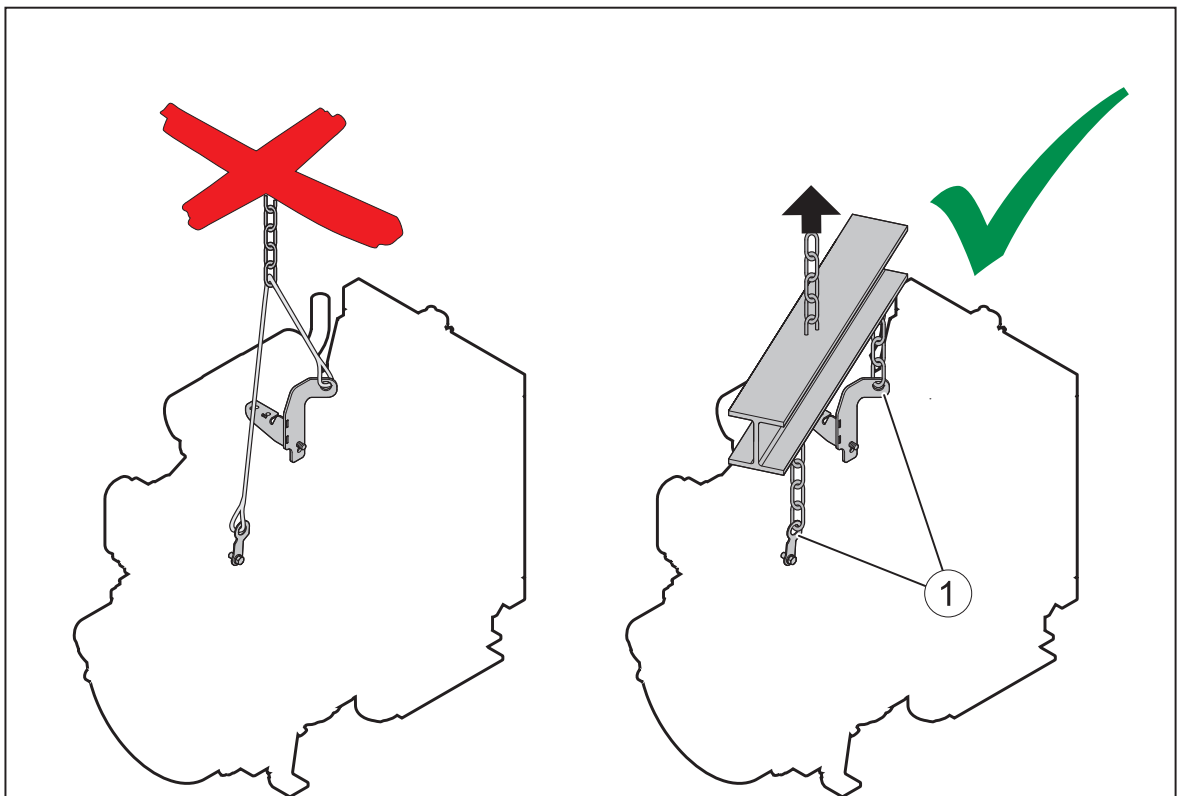

1 | Lifting points

7 Installation

7.1 Installation notes

The machine manufacturer must follow the applicable regulations regarding machine safety – the engine is a part of a machine.

Depending on the use and installation of the engine, it may be necessary for the machine manufacturer and machine user to install safety equipment to prevent inappropriate use. Note the following:

- Parts of the exhaust gas system and the engine surface become hot during operation and may not be touched until they cool down after the engine is switched off.
- Incorrect cable connections and incorrect operation of the electrical equipment can lead to sparking and must be avoided.
- After the engine is installed in the machine, rotating parts must be protected against contact.
- Comply with all notices and warning labels on the engine and keep them in a legible condition. If a label should become detached or difficult to read, it must be replaced promptly. For this purpose, contact your nearest **HATZ Service**.
- Any improper modification of the engine will result in a loss of liability coverage for resulting damage.

Only regular maintenance, as specified in this manual, will maintain the operating readiness of the engine.

The **installation instructions** contain important information on how to safely assemble the engine. If you have any questions, please contact your nearest **HATZ Service** before commissioning the engine.

7.1.1 Torques and screw classification

NOTICE	
	<p>To ensure proper screw connections, the specifications in the list Torques + classification057005xx must be adhered to for every installation.</p> <p>For a category A screw connection, there are additional requirements that need to be adhered to.</p> <p>The current list can be downloaded at the following link: www.hatz.com/docu.</p>

7.2 Engine suspension

Good operating performance of the machine can be realized neither by the engine nor by the machine to be driven alone, rather the two components must be appropriately and properly matched to each other.

Generally, flexible mounting of the engine should be aimed at. In addition, ensure that the engine is uniformly loaded; see chapter *7.2.4 Uniform bearing load, page 29*.

If there is any doubt, please contact your nearest **Hatz service station**.

7.2.1 Engine brackets

Open Power Unit

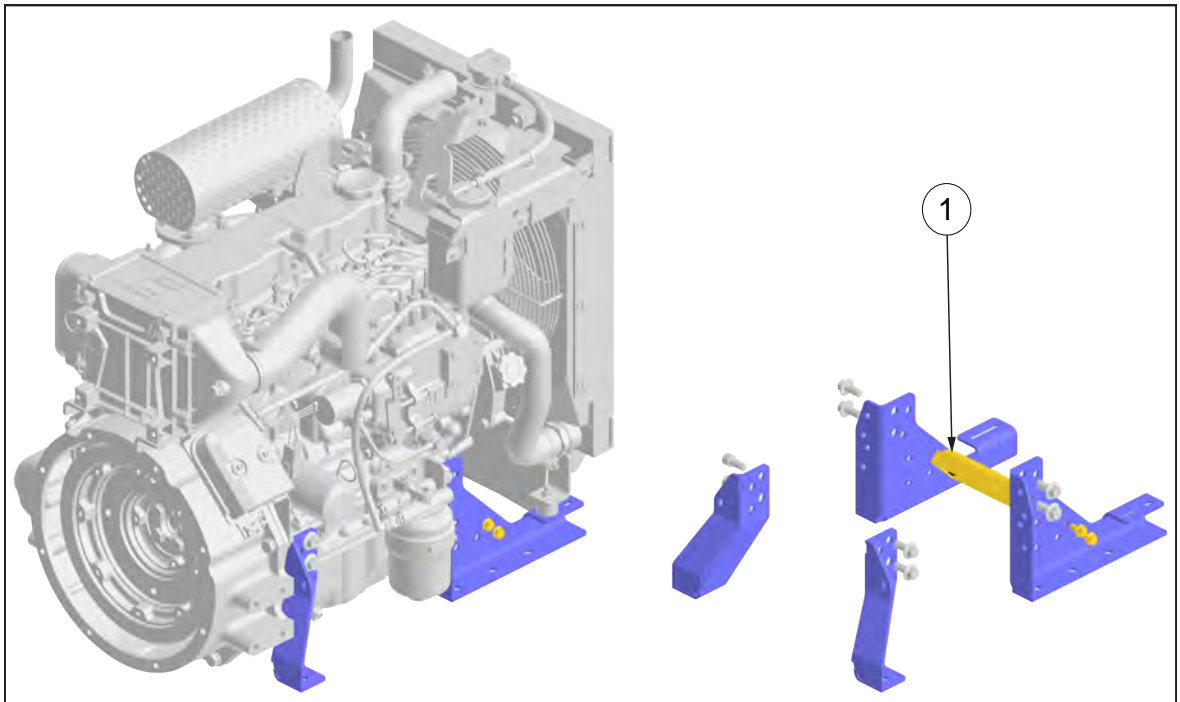

To ensure the mechanical stability, bearing life and functional reliability of the system **when using a second belt track**, the engine bracket (pos. 1) must be additionally stiffened.

For details, see 7.9.2 Main power take off – timing cover side (belt drive), page 59.

7.2.2 Flexible engine mounting - Vibration damper

Vibration damper

The support surface for the fixing of the engine must comply with a flatness tolerance of max. 1 mm. The engine is not permitted to be mounted on painted surfaces.

NOTICE	
	<p>Depending on the application, the device manufacturer must define and set up the installation of the engine together with the appropriate vibration dampers.</p> <p>For engine installations on mobile machines (such as vehicles, trailers etc.), the engine must be secured against transverse forces. For this, either vibration dampers with a breakaway or separate mechanical safety elements should be used (e.g., arrestor cables). For this purpose, contact your nearest Hatz service.</p>

Pos.	Material no.	Vibration damper	Ø [mm]	h [mm]	Hardness [Shore]
1	502 602 00	Cylindrical rubber buffer A (M10x30)	70	45	55
2	502 603 00	Cylindrical rubber buffer A (M10x30)	70	45	65
3	506 617 00	Cylindrical rubber buffer B (M10x30)	70	45	55
4	506 618 00	Cylindrical rubber buffer B (M10x30)	70	45	70
5	503 236 00	Hydro mount V12/600 (M10)	45/64	32/91	45
6	402 173 00	Hydro mount V1500 (M12)	64/89	44/103	55
7	507 028 00	Hydro mount medium (M12x30)	60/63	45/96	40
8	506 679 00	Mounting foot with breakaway (M10)	58.5/77	30	40

Pos.	Material no.	Vibration damper	Ø [mm]	h [mm]	Hardness [Shore]
9	506 678 00	Mounting foot with breakaway (M10)	58.5/77	30/31	60
10	506 947 00	Mounting foot with breakaway (M10) highly damping	58.5/78	31	50
11	043 884 00	Spacer (M10)	55	32	

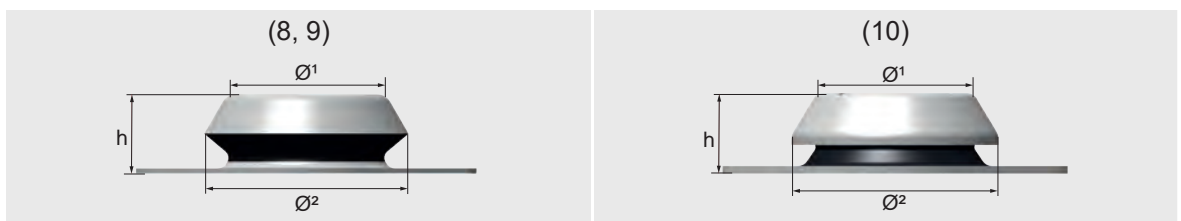
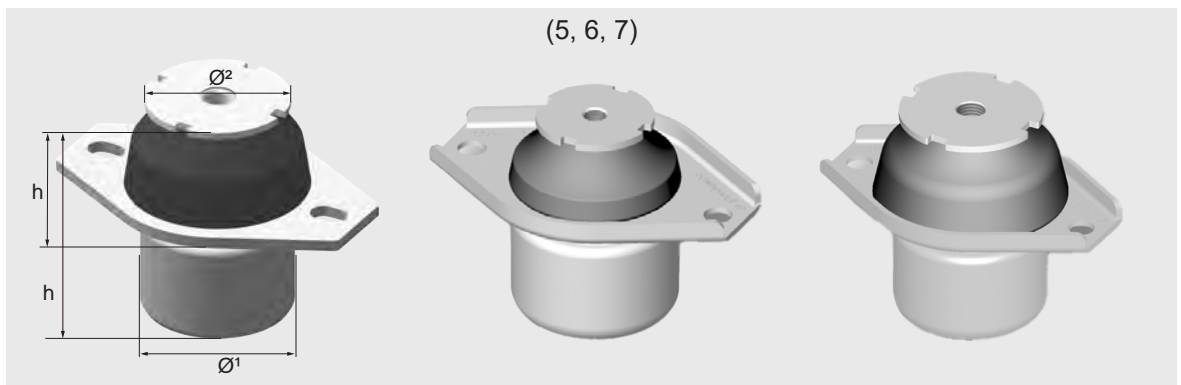
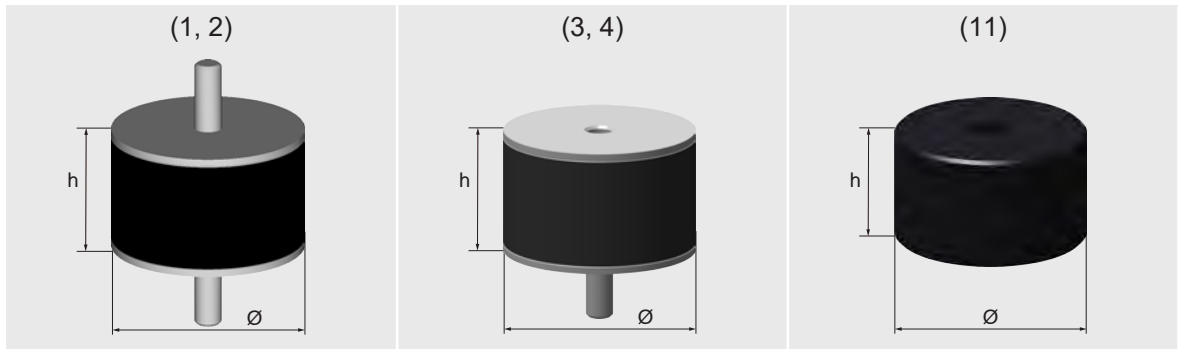

Fastener kits

Engine type					
BFS	3F35	3F45	3F45E	4F45	4F45E
<i>7.2.2.1 Schwingungsdämpfer (Pos.), page 25</i>					
I				1, 2	1, 2
II	11			3, 4, 5, 8, 9, 10	3, 4, 5, 8, 9, 10
III		6, 7	6, 7		

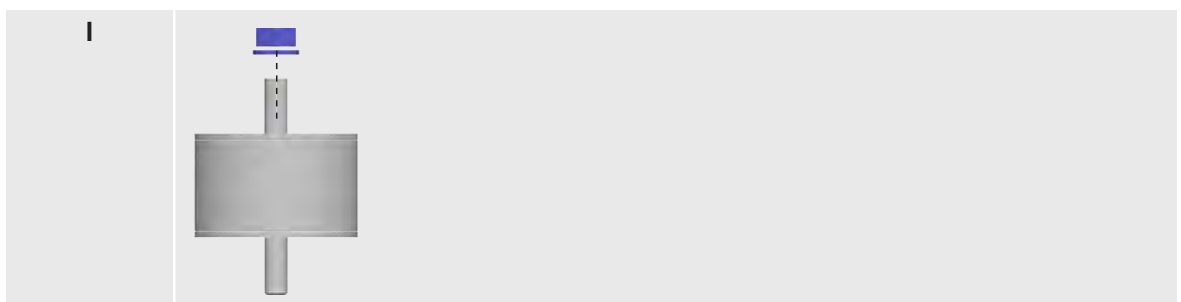

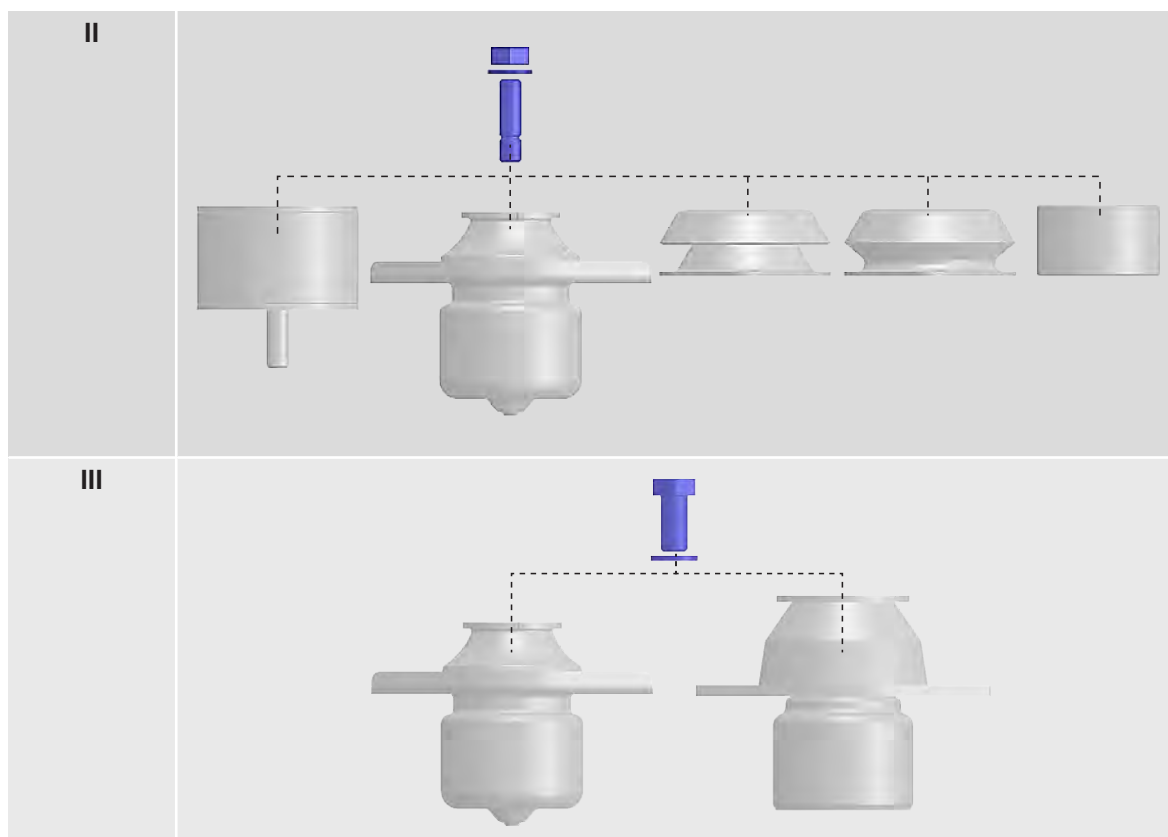



Tightening torques of nuts, screws and set screws

M10 → 46 Nm (BFS I / II)

M12 → 80 Nm (BFS III)

7.2.3 Rigid engine suspension

 CAUTION
 <p>Danger of injury and danger of engine damage if the engine is not mounted without stress</p> <ul style="list-style-type: none"> ▪ If the engine fastening is rigid, the engine brackets with the baseplate must be set up in a stress-free manner (flatness tolerance of the contact surface must be 0.2 mm). ▪ The engine is not permitted to be mounted on painted surfaces. ▪ Non-observance can lead to a risk of injury, breaking of the engine brackets/baseplate, and thus engine damage.

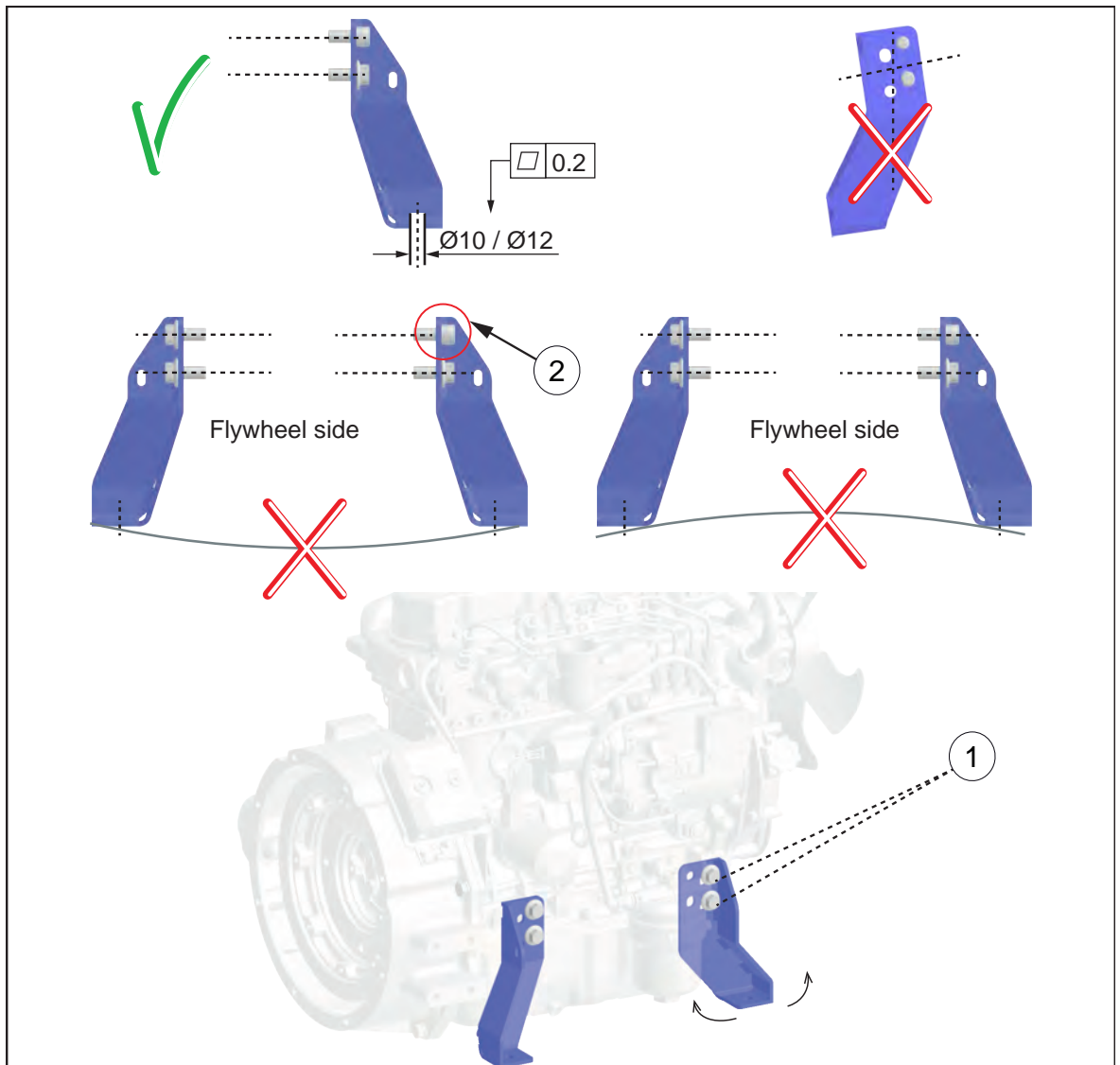

Tightening torque: (1) hex screw M10 (58 Nm), M12 (104 Nm); (2) cylinder head screw (93 Nm)

In order for the engine to be installed absolutely free of stress, the 4th engine bracket must be aligned with the contact surface; see engine bracket (1). First release the screws and then align. Afterward, tighten the screws to the tightening torque.

Rigid mounting is only allowed up to an engine speed of approx. 1,800 rpm. In addition, the free mass forces are typically so large that only a flexible support makes sense.

Prerequisite for each engine mount: The frame must be intrinsically rigid and sufficiently strong. Parts of the frame that are not rigid act like springs and must be stiffened by braces.

If the **engine speed in a rigid setup should be > 1800 rpm**, Hatz must be consulted to determine if the application can be approved.

7.2.4 Uniform bearing load

When using bearing elements, ensure the bearing load is uniform. No more than 60% of the total weight should rest on A or B; if in doubt, contact your nearest **Hatz service center**.

Determination of bearing forces (if centers of gravity of the engine, attachments such as hydraulic pump, generator, and their intrinsic weights are known)

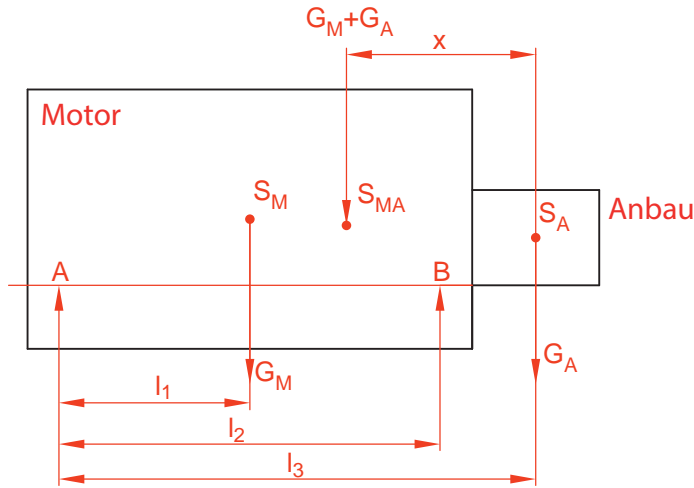

$$A = \frac{G_M \times (l_2 - l_1) - G_A \times (l_3 - l_2)}{l_2} \text{ [N]}$$

$$B = \frac{(G_M \times l_1) + (G_A \times l_3)}{l_2} \text{ [N]}$$

Abbrevia-tion	Meaning
S _M	Center of gravity of engine
S _A	Center of gravity of attachment (e.g. hydraulic pump, alternator,...)
S _{MA}	Overall center of gravity (engine + attachment)
G _M	Engine weight force[N]
G _A	Attachment weight force [N] (e.g., hydraulic pump, generator etc.)
A	Bearing load A
B	Bearing load B
L _{1,2,3}	Distances [m]

For the position of the overall center of gravity (engine with attachment):

$$x = \frac{l_3 - l_1}{1 + \frac{(G_A)}{(G_M)}} \text{ [m]}$$

7.3 Engine cooling

For the maximum permissible coolant temperature, see section 4.1 *Engine information and filling quantities*, page 16.

The cooler and the coolant reservoir, hoses, gaskets, etc., **must not** contain non-ferrous metals, i.e. neither copper or zinc compounds.

7.3.1 Installation of the cooler under a cover

The routing of the cooling air flows is critical for reliable cooling of the engine. Therefore, when installing the equipment, ensure that all air routing parts are correctly aligned and attached.

Example of an extractor fan:

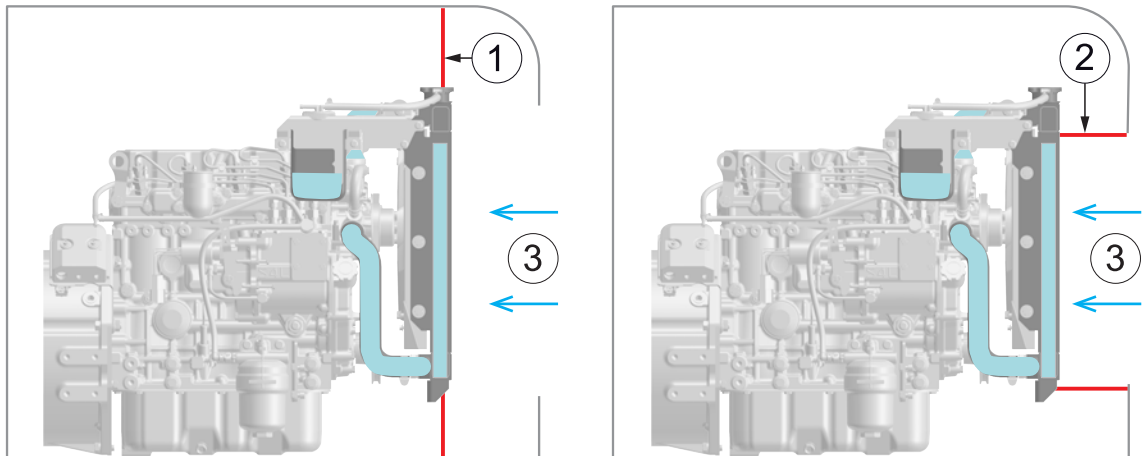

1	Separation
2	Cooling air duct
3	Air flow

The connections of the separating plates to the cooler must be flexible in design (e.g. rubber sealing lip). The separating plates must not have an air gap to the cooler and must have a flexible range of min. 10 mm.

Cooling air duct:

- Calculation of the front cooling area of the cooler (A_{cooler})

$$A_{\text{cooler}} = W \times H \quad (W: \text{width of the cooler core, } H: \text{height of the cooler core})$$

- Minimum requirements for the air intake area**

For **applications with a pressure fan**, the air intake area of the engine hood must be twice the size of the cooler core area.

$$A_{\text{intake}} \geq 2 \times A_{\text{cooler}}$$

- For **applications with an extractor fan**, the air intake area must be larger than the cooler core area.

$$A_{\text{intake}} \geq 1 \times A_{\text{cooler}}$$

- Minimum requirements for the air outlet area**

The air outlet area must be at least as large as the air intake area.

Recommendation: $A_{\text{outlet}} \geq A_{\text{intake}}$

If there is a 90° deflection or acoustic damping, it must be greater by 20–50%.

7.3.2 Amount of heat to be dissipated at the full load curve (100 % engine load)

3F30 - Main cooler flow rate[l/Min] - pressure fan

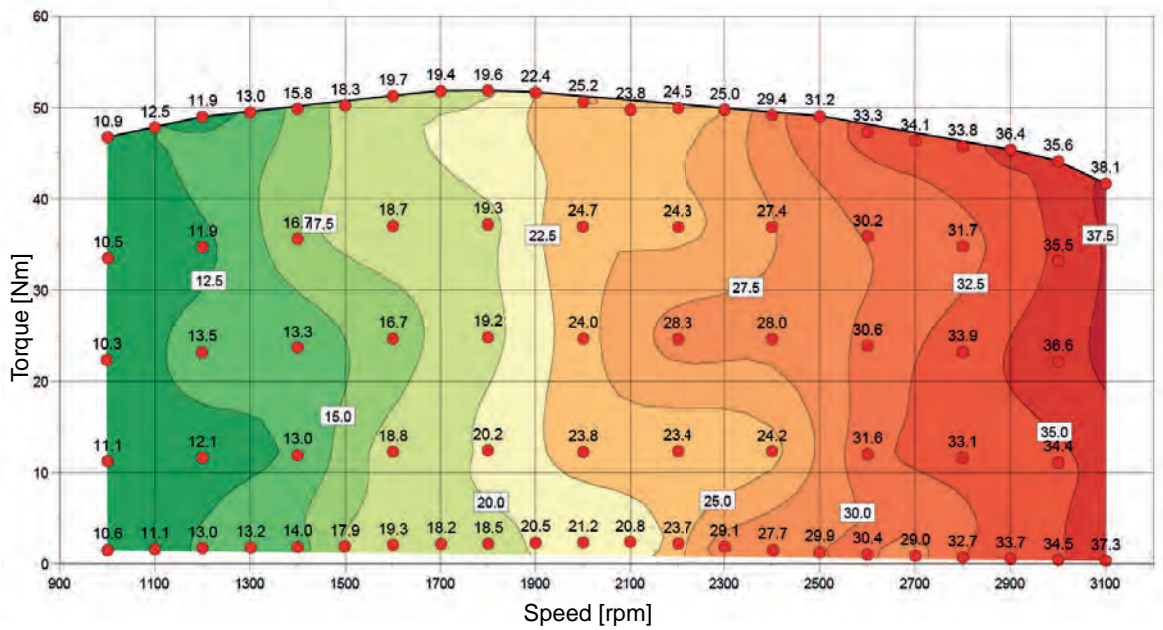

3F30 - Main cooler cooling capacity [kW] - pressure fan

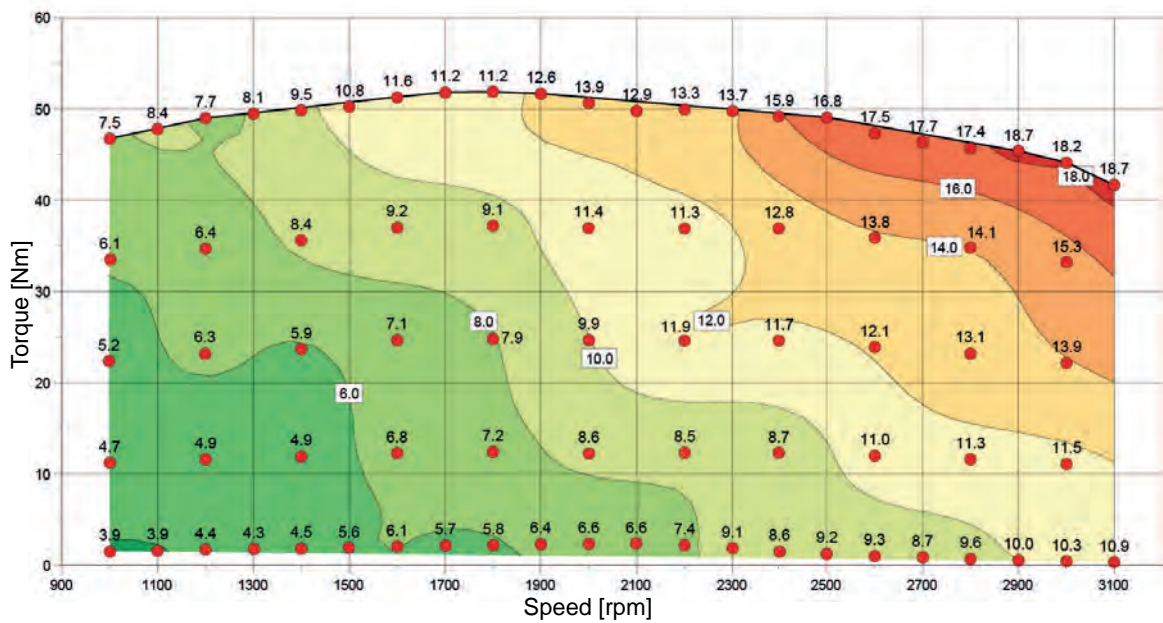

3F30 - Main cooler flow rate[l/Min] - extractor fan

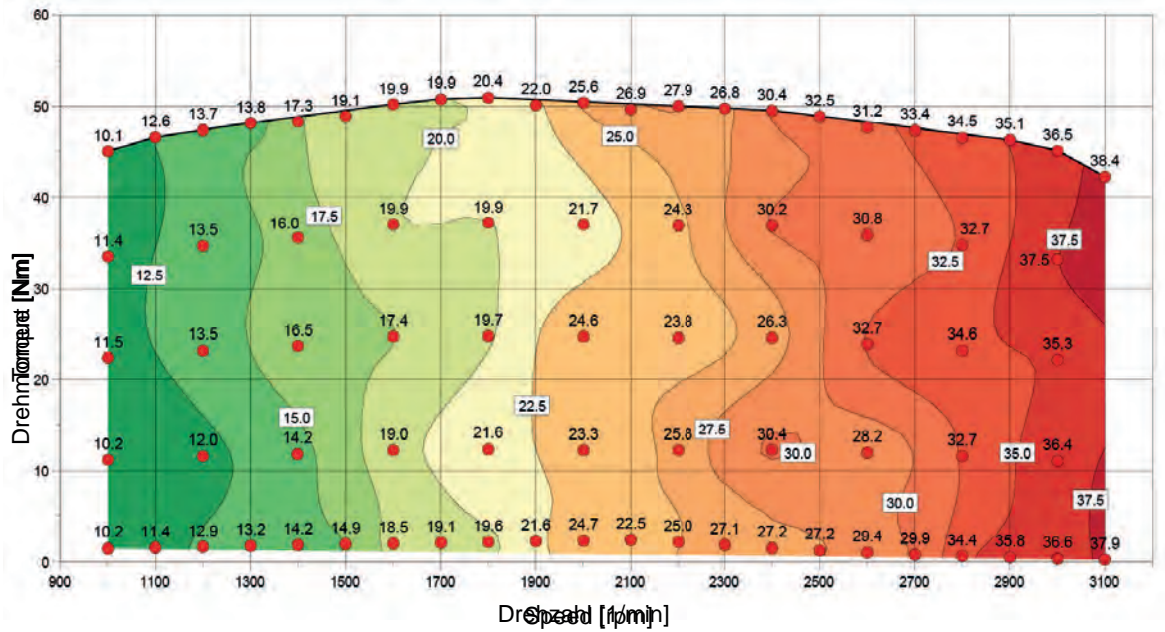

3F30 - Main cooler cooling capacity [kW] - extractor fan

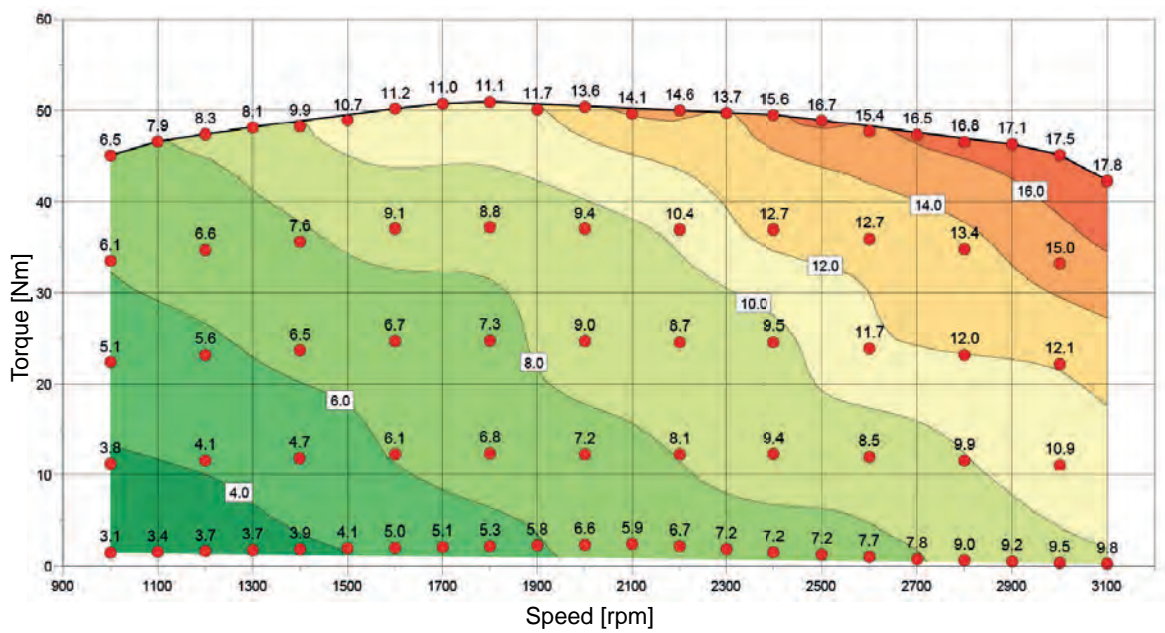

3F45 - Main cooler flow rate[l/Min] - extractor fan

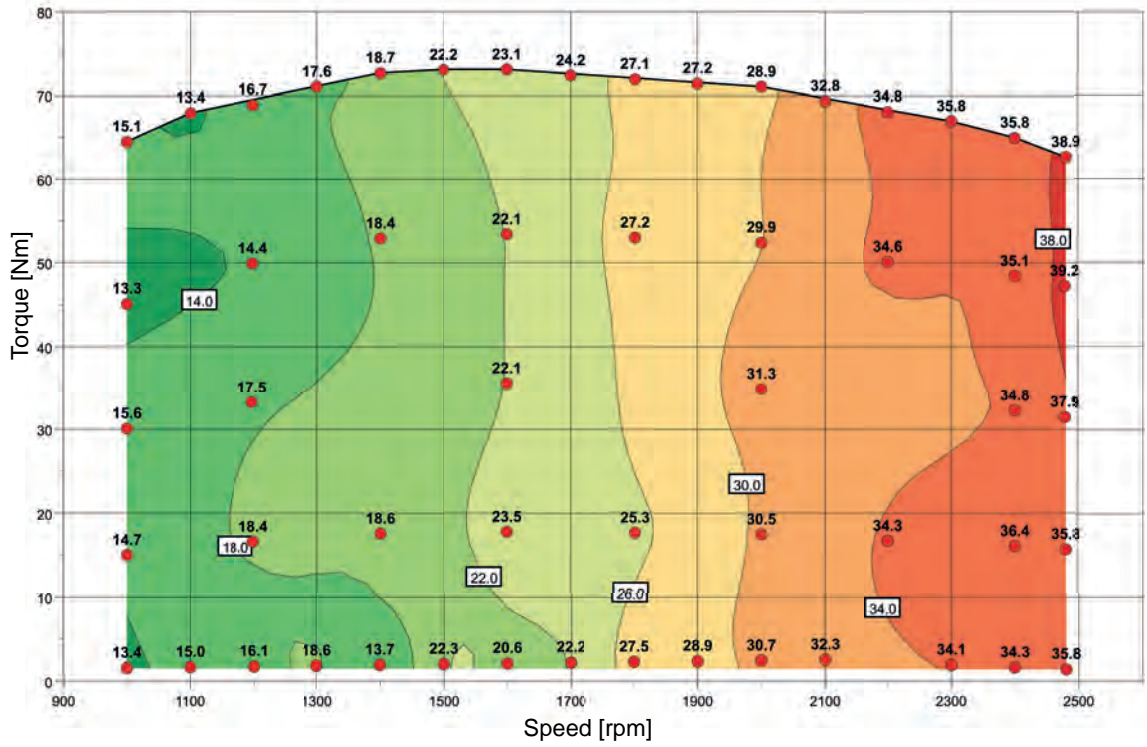

3F45 - Main cooler cooling capacity [kW] - extractor fan

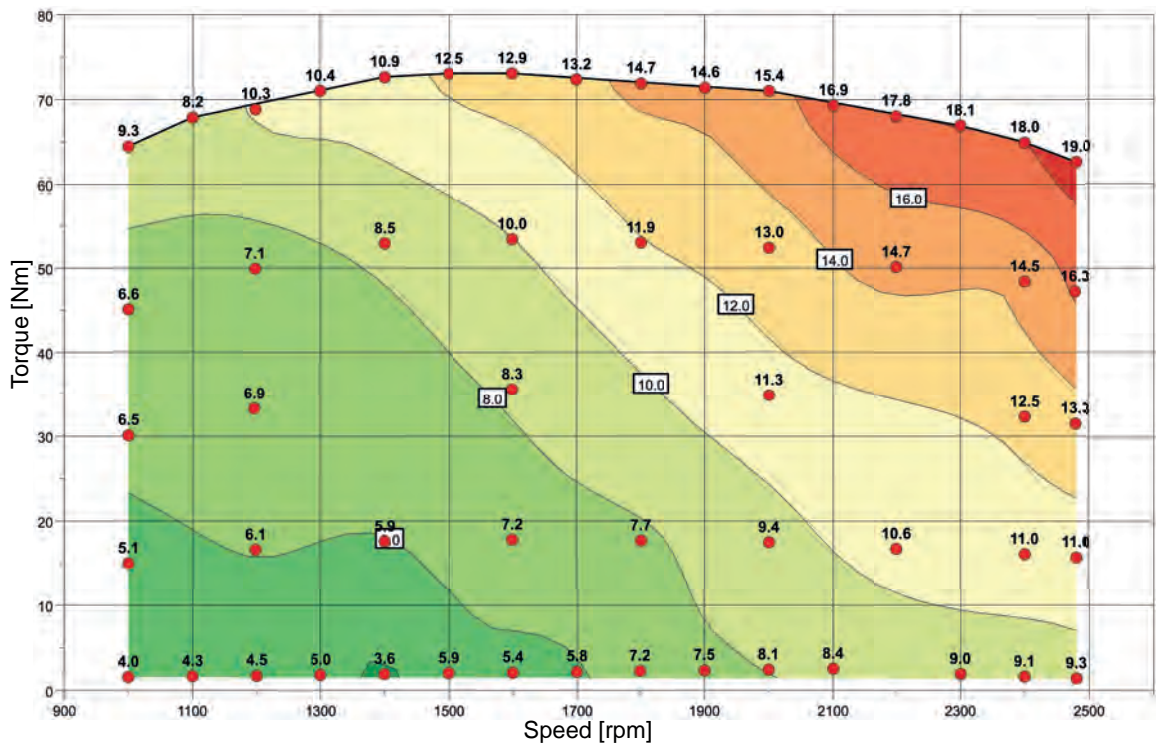

4F45 - Main cooler flow rate[l/Min] - pressure fan

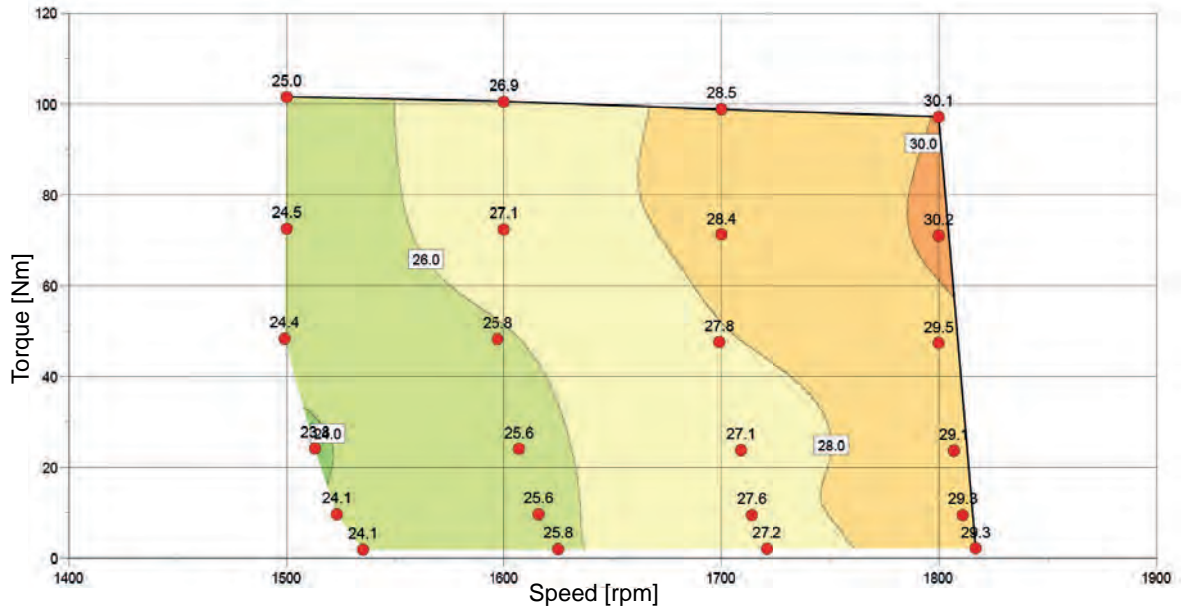

4F45 - Main cooler cooling capacity [kW] - pressure fan

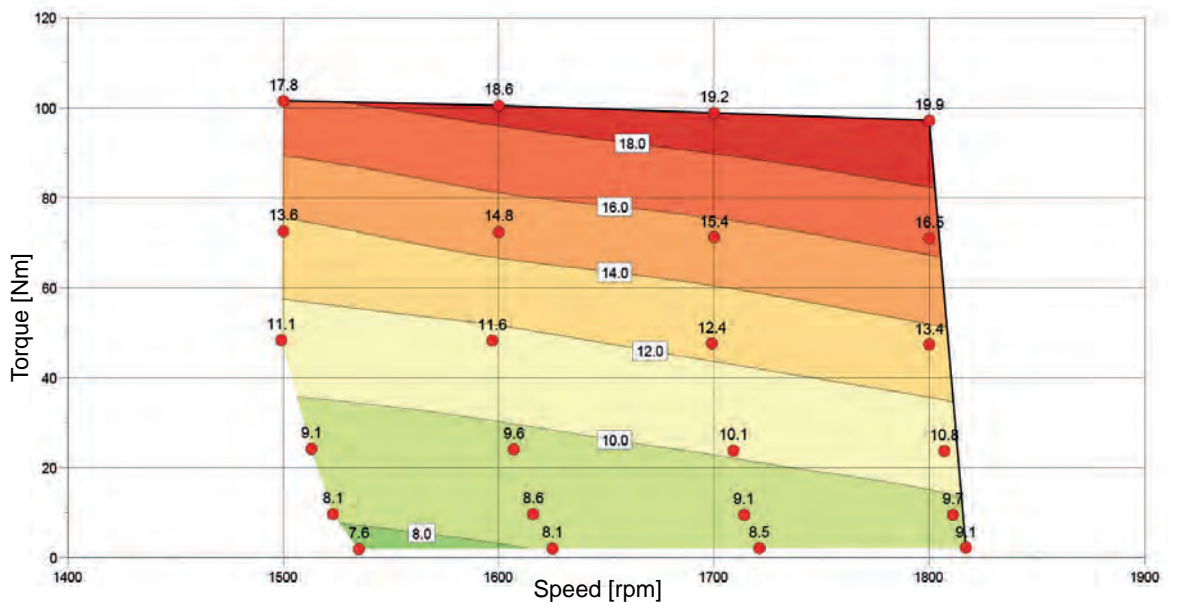

4F45 - Main cooler flow rate[l/Min] - extractor fan

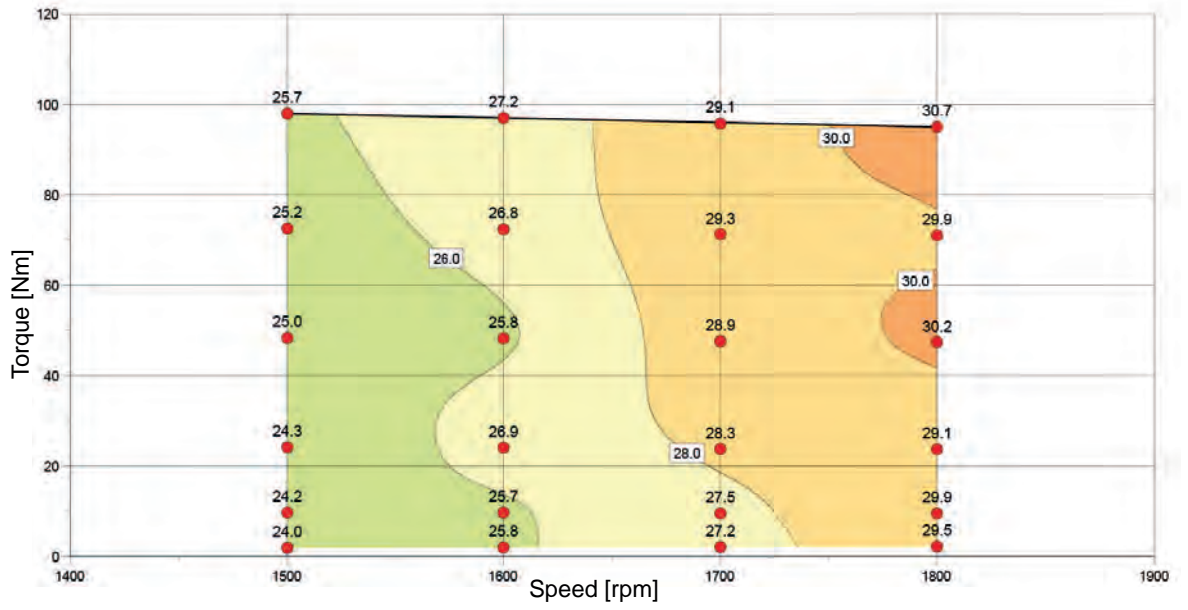

4F45 - Main cooler cooling capacity [kW] - extractor fan

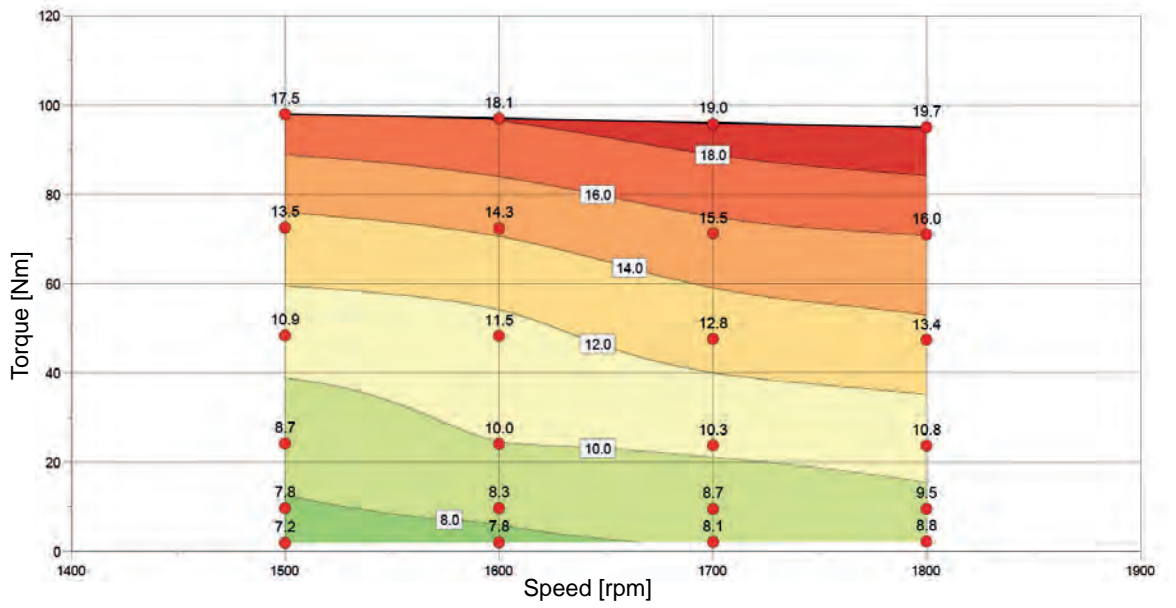

7.4 Fuel system

7.4.1 Fuel circuit diagram - installation of fuel lines

It must be ensured that all other connections of the fuel lines, which are mounted by the customer, are secured using suitable hose clamps (A). Spring band clamps are recommended on the fuel prefilter (I) due to easier maintenance.

After installation, a leak tightness test must be performed on all lines.

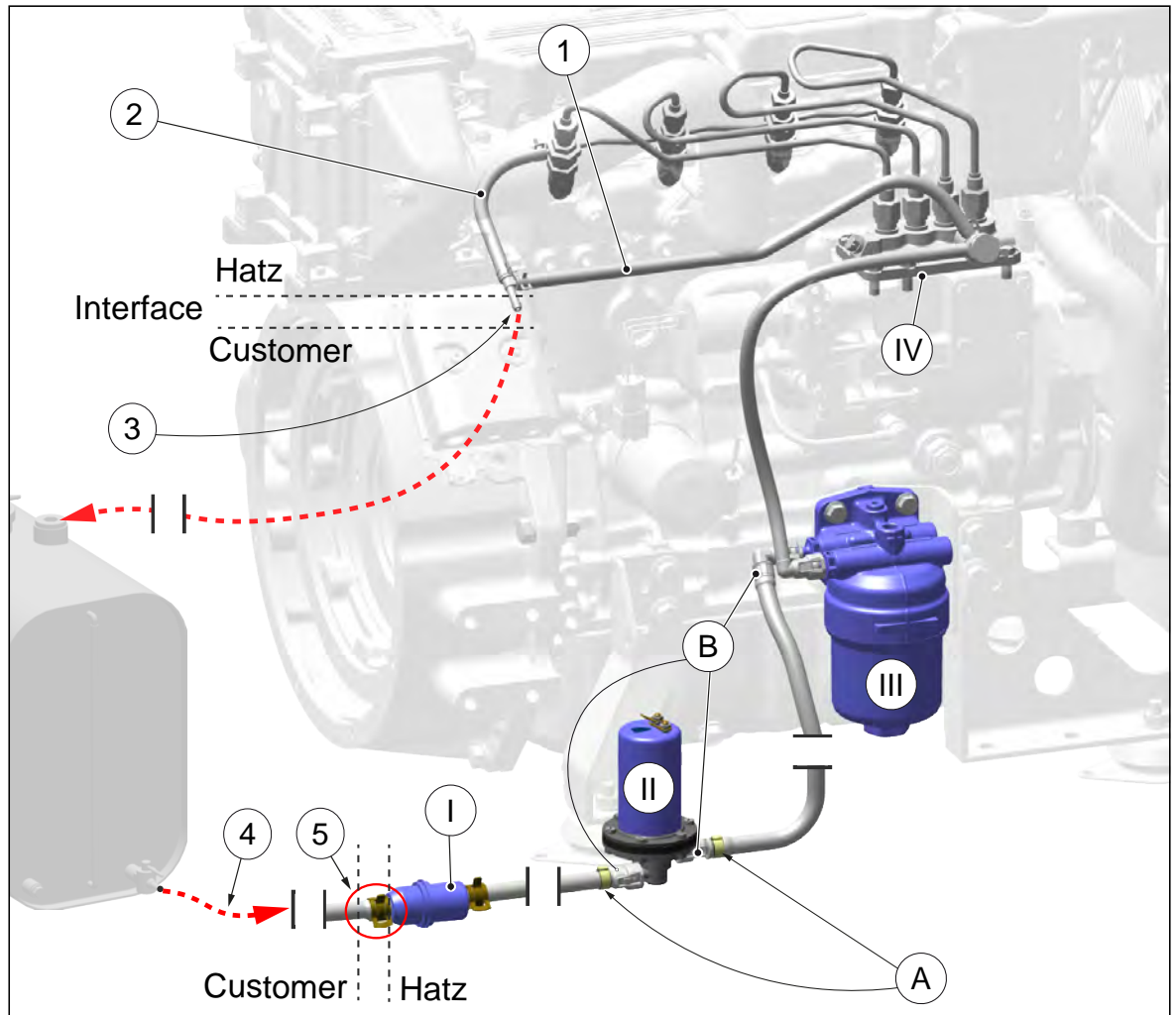

1	Injection pump return feed
2	Return leakage line, injectors
3	Connection point, return line to tank
4	Supply from tank
5	Measuring point, max. permissible negative pressure
I	Fuel prefilter
II	Electric fuel pump
III	Fuel main filter with water separator
IV	Injection pump
A	Hose clamps
B	Quick connectors

Fuel line specification: DIN 73379-8x3-A6, DIN 73379-8x3-B1 or better.

7.4.2 Electric fuel pump

Rated and test voltage	12 V
Start-up voltage	9.0 – 9.5 V
Supply/return length with Ø 8 mm	Max. 5 m*
Permitted negative pressure at delivery pump	0.3 bar (pos. 5)**
Current consumption at system pressure	≤ 1.9 A
Flow rate at system pressure	100 – 130 l/h
Static pressure	0.28 – 0.35 bar

*The specified pressures and volumes are important in all cases.

** See 7.4.1 Fuel circuit diagram - installation of fuel lines, page 36.

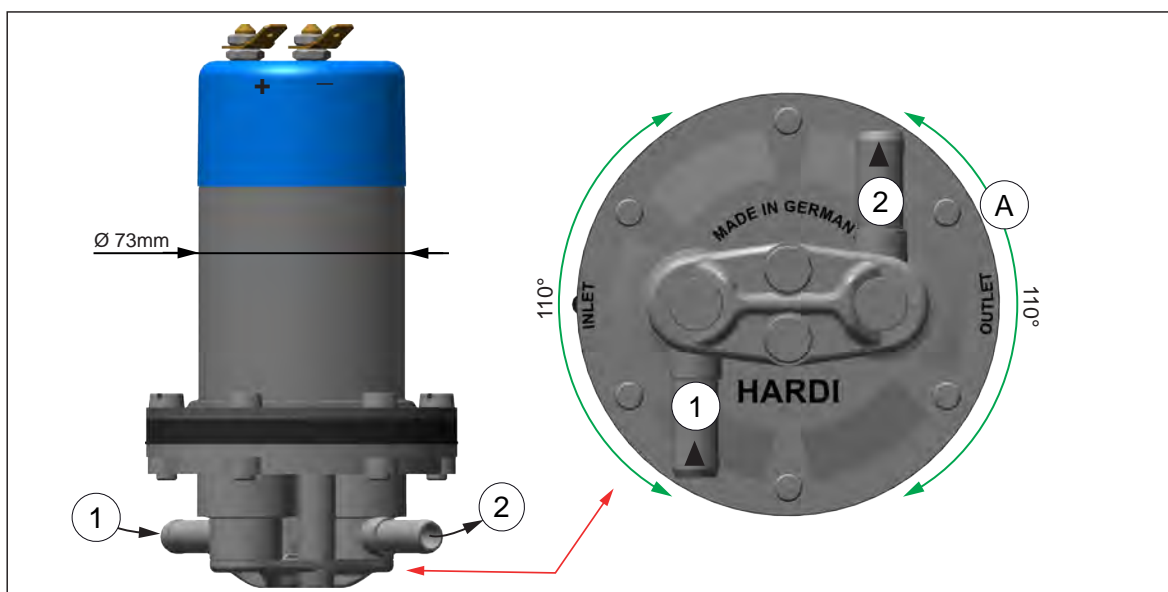

Pos	Designation
A	Hose connections that can be swiveled by 110° (Ø 8 mm)
1	Intake side (supply from tank)
2	Pressure side (flow to main fuel filter)

The electric fuel pump must be mounted using a suitable fastening clamp (rubberized). Mounting of the fuel pump directly on the engine is not permitted due to engine vibrations!

7.4.3 Fuel main filter

⚠
WARNING

Danger of injury due to fuel splashes.

Fuel can exit under pressure when the main fuel filter is removed.

- Carefully remove the main fuel filter.
- Wear safety goggles.

Due to the different ways of storing fuel in the various fields of application, the fuel cleanliness cannot always be guaranteed. Condensation and deposits can occur in the fuel. For this reason, the fuel main filter pos. 1 must contain a water separator pos. 2 (tightening torque 5 Nm).



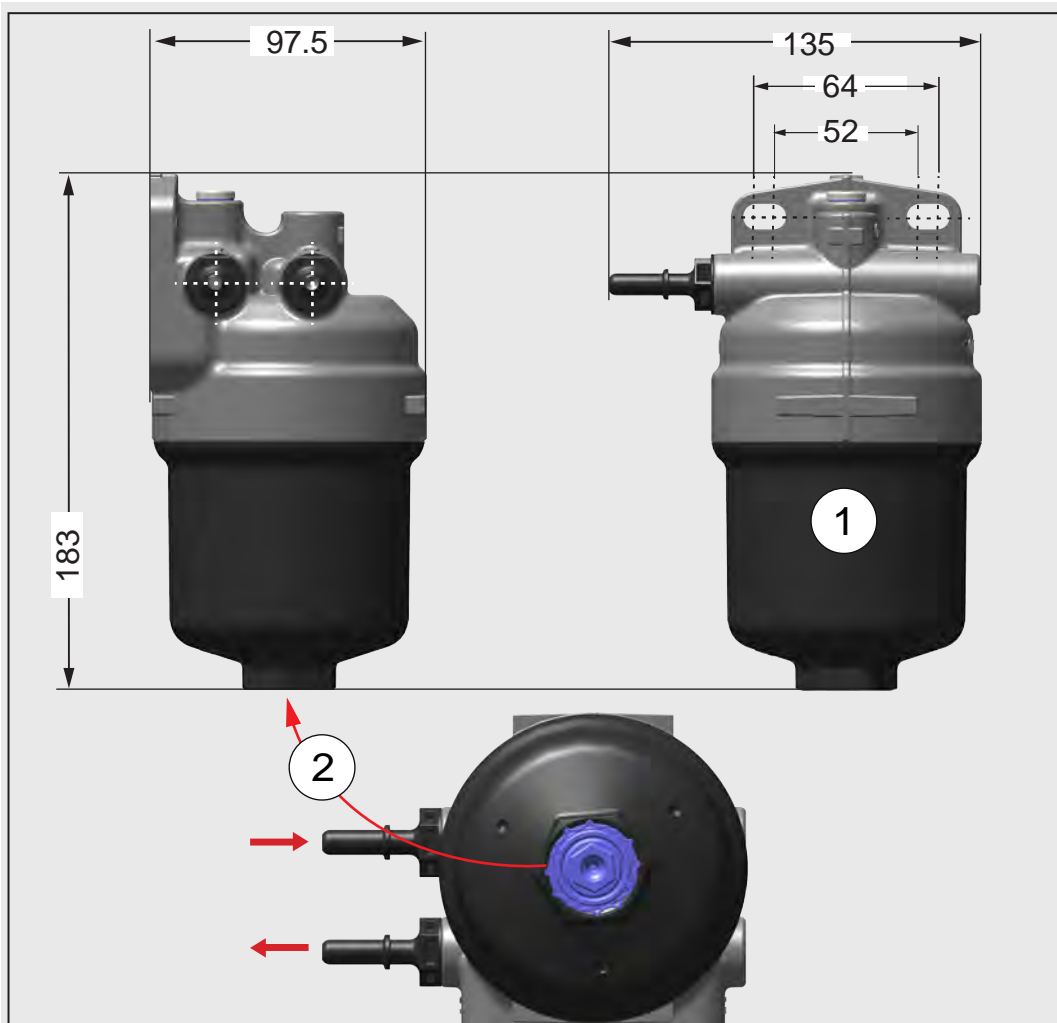

The engine may only be operated with fuel main filters from Motorenfabrik Hatz – other brands are not permissible!



Technical data:

Flow rate nominal/max.	100 l/h	200 l/h
Ambient temperature min./max.	-30 °C	120 °C
Fuel temperature min./max.	-30 °C	80 °C
Max. permissible negative pressure in fuel line	0.3 bar	
Separation efficiency 10 µm at nominal flow rate	> 98 %	
Dust absorption at nominal flow rate 40 kPa	> 30 g	
Water separation efficiency 150 µm	< 93 %	
Separation volume 0°/30°	65 ml	10 ml

7.4.4 Fuel tank

 DANGER	
 	<p>Fire hazard from fuel.</p> <p>Leaked or spilled fuel can ignite on hot engine parts and cause serious burn injuries.</p> <ul style="list-style-type: none"> ▪ Only refuel when the engine is switched off and has cooled down. ▪ Never refuel in the vicinity of open flames or sparks that can cause ignition. ▪ Do not smoke. ▪ Do not spill fuel.
 CAUTION	
	<p>Danger of environmental damage from spilled fuel.</p> <p>Do not overfill the fuel tank and do not spill fuel.</p> <ul style="list-style-type: none"> ▪ Collect any leaking fuel and dispose of it according to local environmental regulations.

When an external fuel tank is installed, make sure that it does not have any processing residues, impurities, water etc.

A discharge port must be provided at the lowest point on the fuel tank to drain water and dirt when needed. This is due to deposits and EN 590 fuels with a FAME content of max. 7%. Due to the penetration of water (hygroscopic action of FAME) in the fuel tank, biocultures (fungi) can occur in the transition layer between the fuel and water.

This can cause damage to the injection system, which can lead to failure of the system. It is therefore imperative to keep the fuel tank clean.

NOTICE	
	<p>Never run until the tank is entirely empty. Always fill up with fuel in time to avoid problems with the system ventilation.</p>

Fuel return variants to tank

The **fuel return line to the tank must be introduced under the fuel level** to prevent the lines from emptying. If this is not possible, a check valve, available from **Motorenfabrik Hatz**, must be installed. The permissible pressures must be observed; see section Electric fuel pump.

A check valve in the fuel supply before the electric fuel pump (EFP) is not permitted.

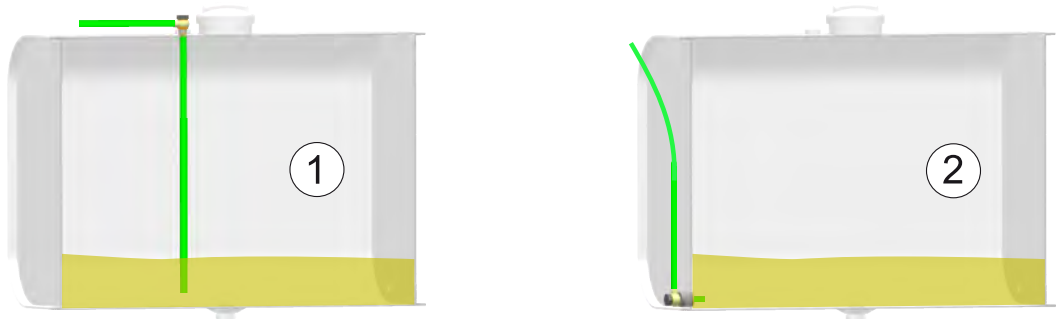



1	Return at the top (with standpipe)
2	Return below the fuel level

The **distance between the supply and return lines** should be as large as possible. It absolutely must be avoided that the warm fuel of the return line can enter into the supply line (thermal short circuit).



3	Supply and return flow – wrong!
4	Supply and return flow – right!

7.5 Exhaust system

⚠ CAUTION	
 	<p>Danger of burns from hot exhaust gas systems.</p> <p>Hot surfaces on the entire exhaust system! Keep explosives and flammable materials away from the engine.</p> <ul style="list-style-type: none"> ▪ Attach the protective device. ▪ Wear safety gloves.
NOTICE	
	<p>The machine manufacturer is obligated to ensure that all safety precautions have been taken in the complete machine so that injuries from hot surfaces can be ruled out.</p>

7.5.1 Dimensioning of the exhaust gas system

CAUTION	
	The exhaust pipe between the engine and the silencer must be gas tight.

The recommended pipe diameter for the continuation of the exhaust pipe corresponds to the outside diameter of the muffler outlet (\varnothing 38 mm). It should be noted that pipe elbows from 45° significantly affect the exhaust gas back pressure!

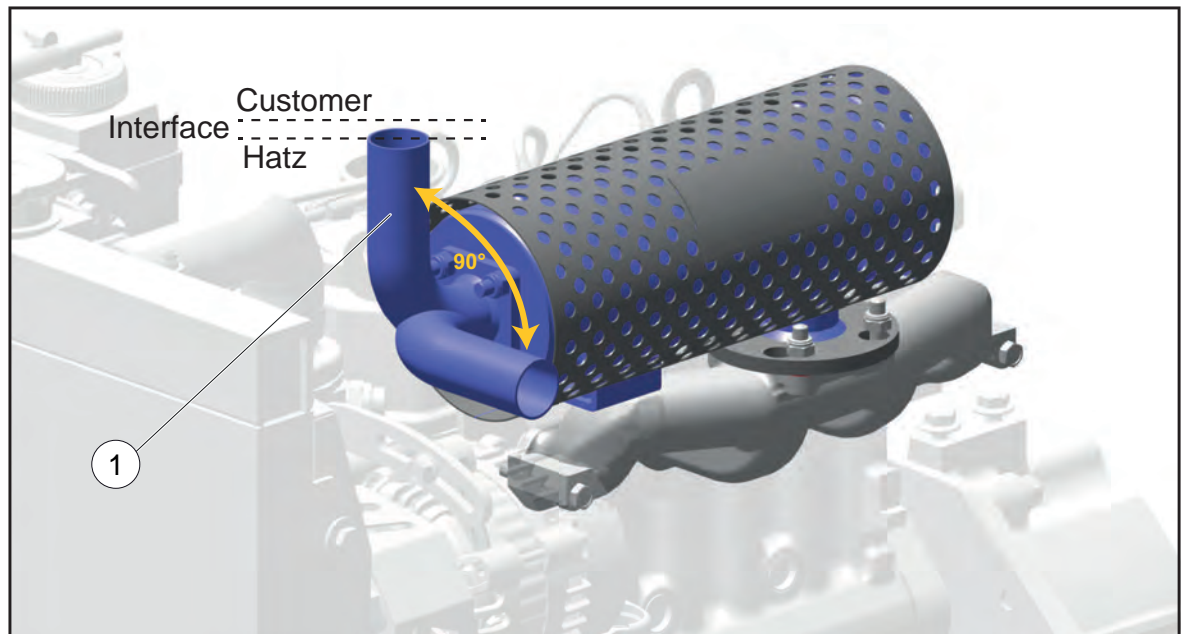

Observe the following regarding the **exhaust pipes**:

- In the case of long exhaust pipes, the conductor cross-section must not be reduced downstream of the muffler outlet (pos. 1) under any circumstances.
- Depending on the installation situation of the engine, the muffler outlet pipe (pos. 1) can be oriented in two different 90° positions by removing and reinstalling it.
- When installing the exhaust pipe, an expansion joint is required to compensate the engine movement. It must be installed close to the pivot point of the elastic bearing. A fixed point is required after the compensator.
- Prevent water from entering the exhaust pipe, e.g., by means of flaps or suitable pipe elbows at the end.
- In long exhaust pipes and when engine utilization is low, the exhaust gas condenses. A condensate drain is required at the lowest point of the exhaust system, enabling the condensate to drain with the aid of gravity.

- Keep the exhaust gas back pressure within the permissible tolerance window in relation to the possible pipe lengths and number of pipe elbows.

The **exhaust gas back pressure and exhaust gas flow rate** for engine specifications 3F30 and 3F45E can be taken from the following maps. For all other engine specifications, contact **Motorenfabrik Hatz**.

3F45E – Exhaust gas back pressure upstream of muffler [mbar rel.]

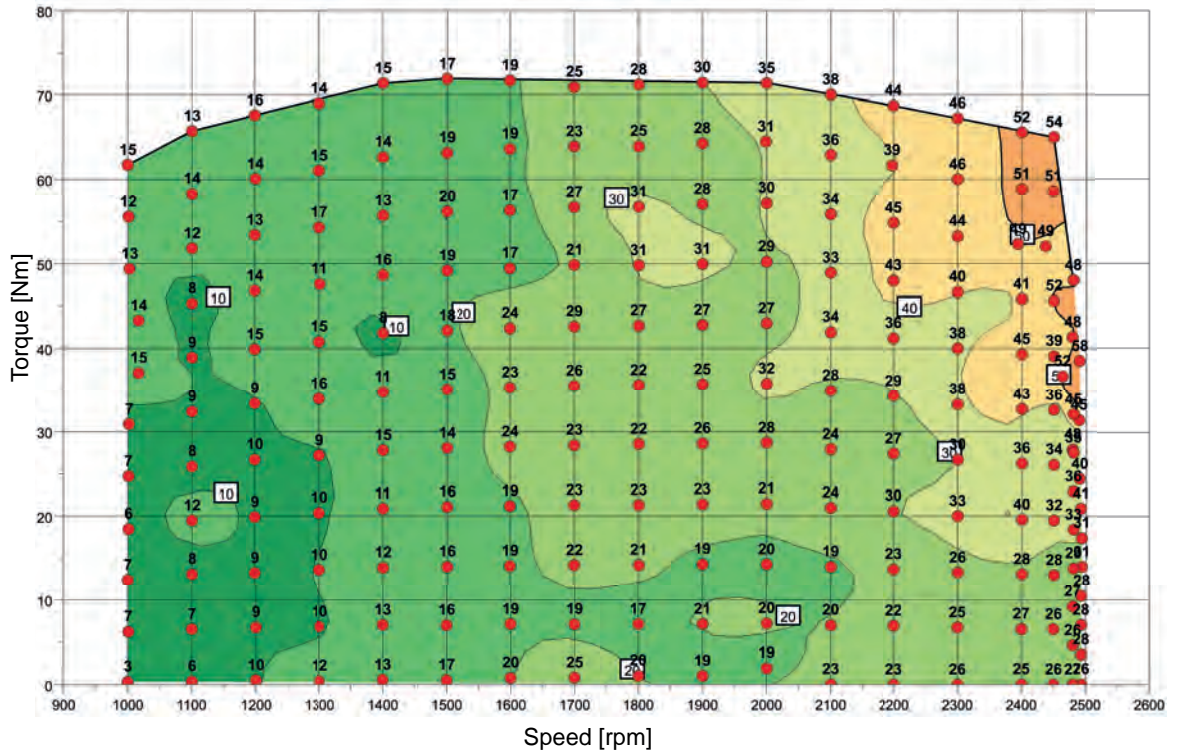

3F45E – Exhaust gas flow rate [m³/h]

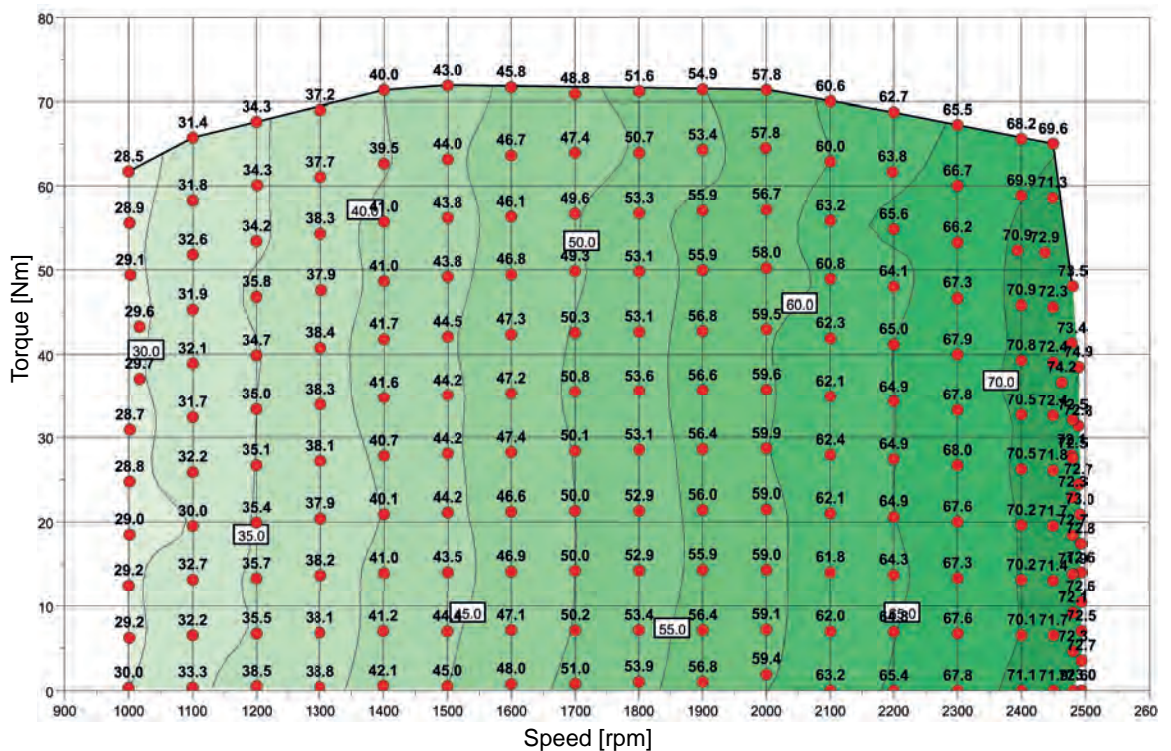

3F30 – Exhaust gas back pressure upstream of muffler [mbar rel.]

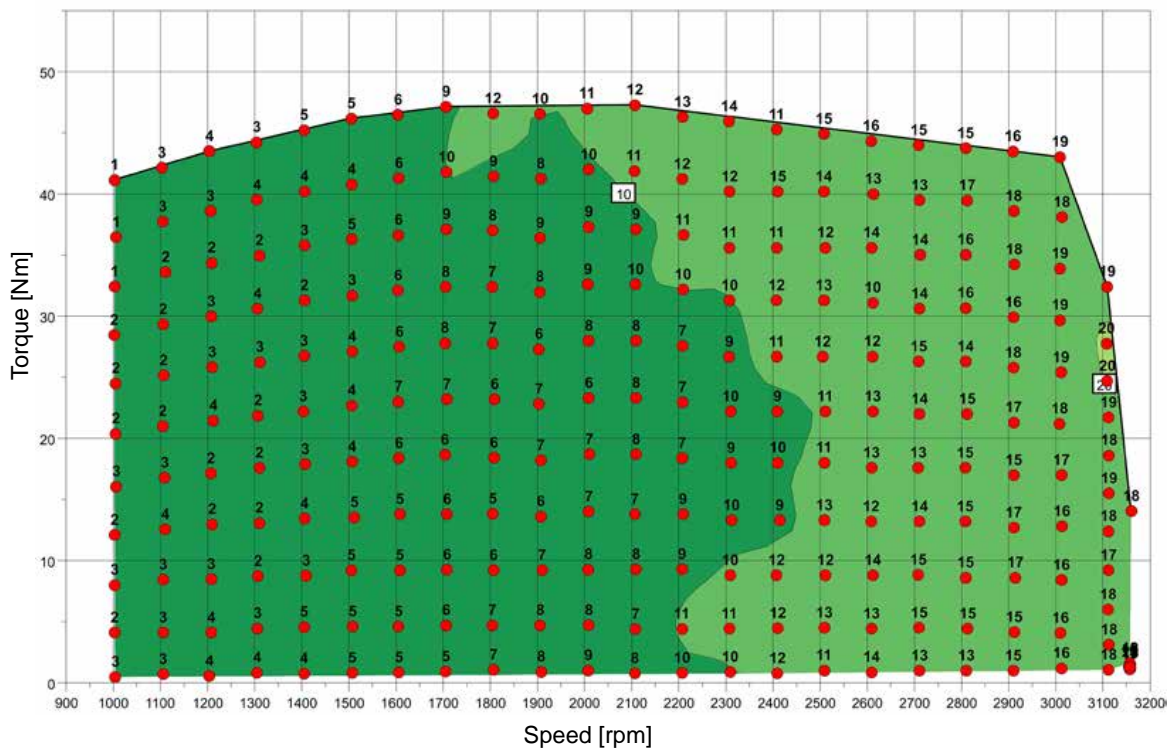

7.6 Intake and combustion air

The measuring point for determining the intake vacuum is 50 mm before the inlet of the intake manifold (pos. 1).

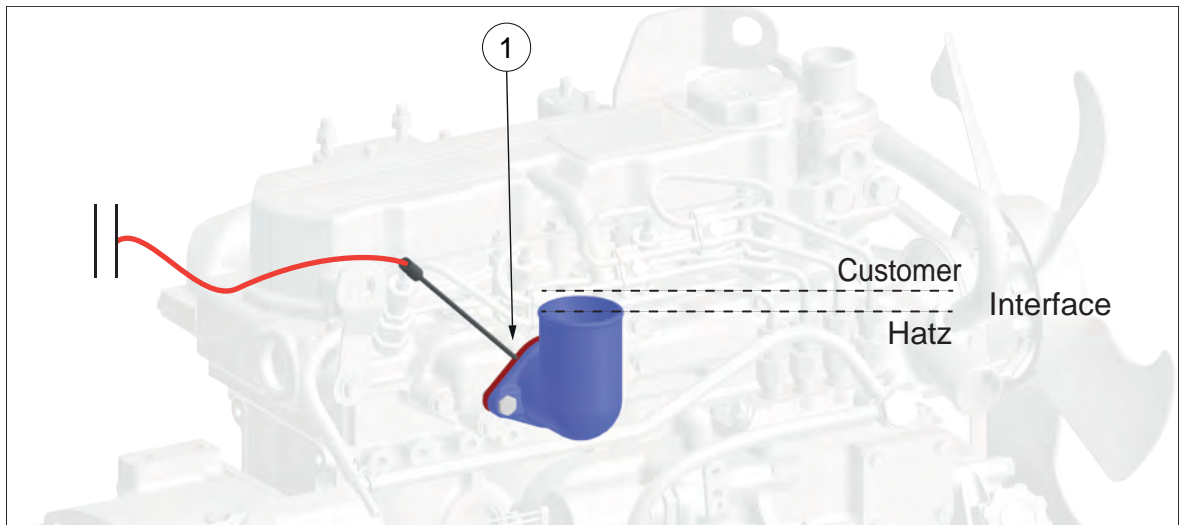

The **maximum permissible intake vacuum** for the engine specifications 3F30, 3F35E, 3F45E and 4F45 can be taken from the following maps.

3F30 – Permissible intake vacuum [mbar rel.]

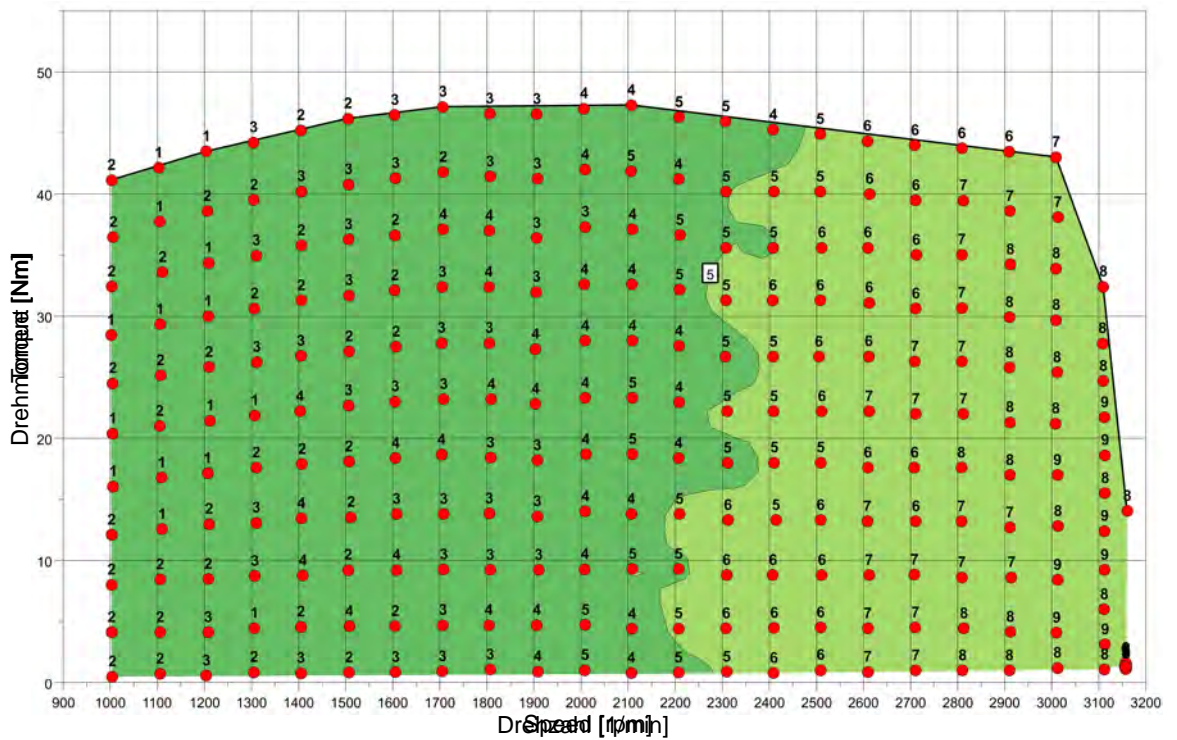

3F35E – Permissible intake vacuum [mbar rel.]

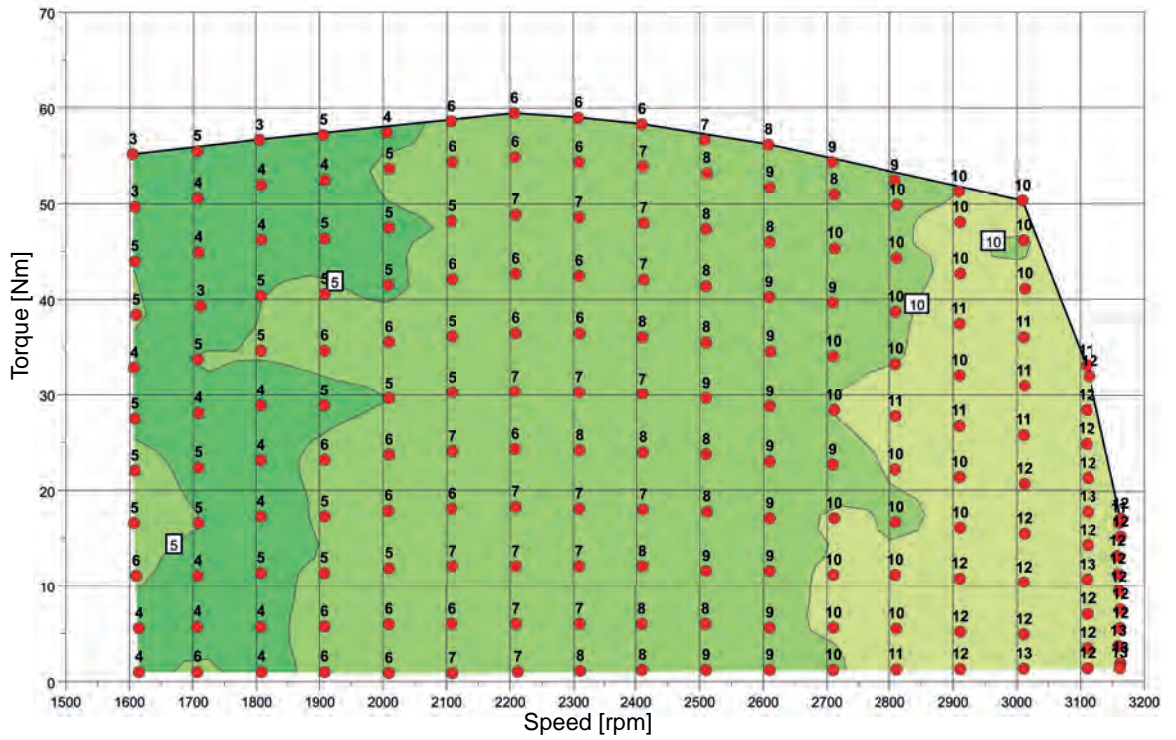

3F45E – Permissible intake vacuum [mbar rel.]

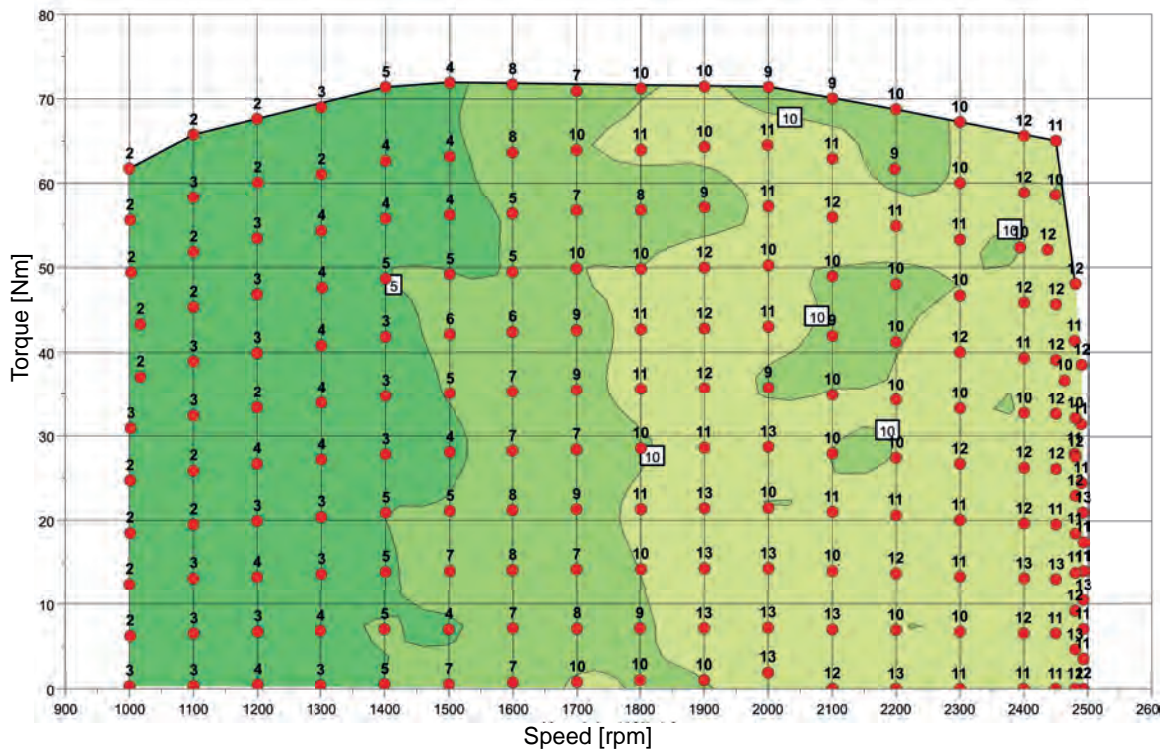

4F45 – Permissible intake vacuum [mbar rel.]

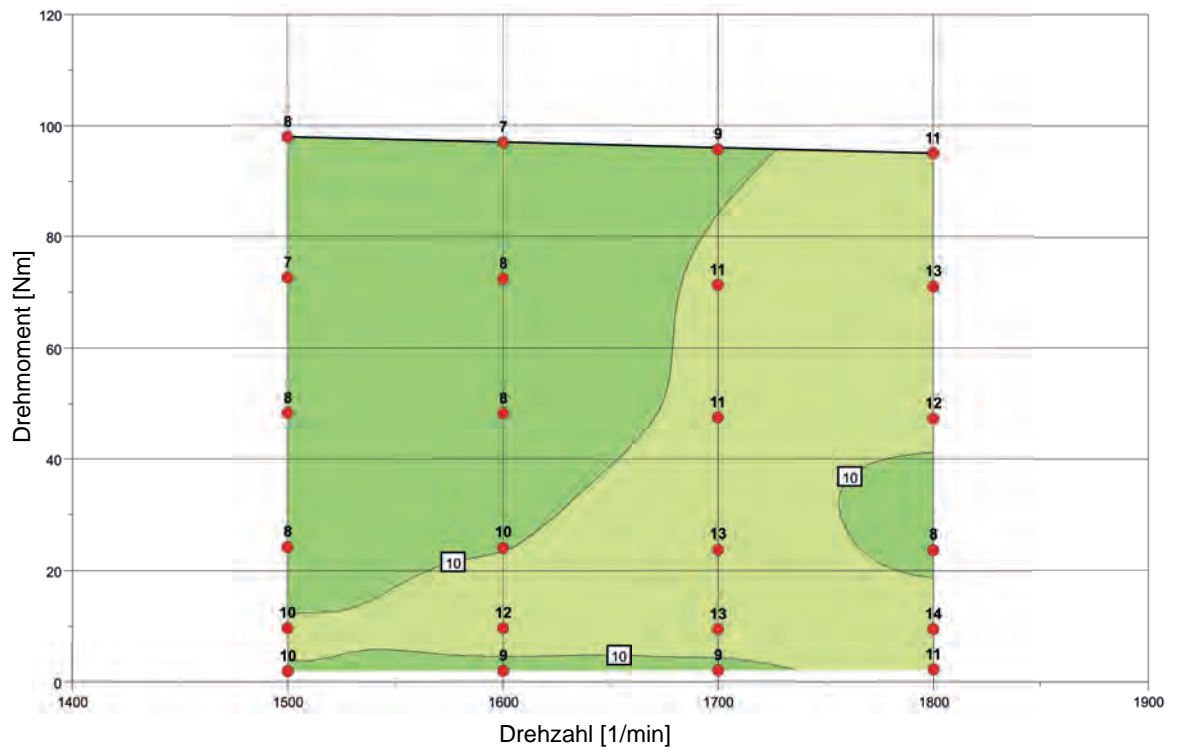

7.6.1 Intake section

Leaks on the clean air side must be avoided. The intake line must be resistant to the pulsation in the intake air and to the engine vibrations. For example, a hose with a spiral wire insert would therefore be suitable as the line material.

CAUTION	
	<p>Note the following regarding hoses with spiral wire inserts:</p> <ul style="list-style-type: none"> ▪ In very dusty and dirty environments, the hose needs to be checked regularly for leaks. ▪ The hose is very thin between the spirals (1.5 – 2 mm). Do not touch with sharp or pointed objects. ▪ Because the hose has low strength, no pressure is permitted to be applied to the hose. ▪ Minimum bending radius = 105 mm ▪ The hose has good resistance to oil, but is not approved for permanent contact with oil.

CAUTION	
	The intake system line must be gas-tight .

The following hoses are recommended with the fitting hose diameter both upstream of the air filter as well as between the air filter and engine.

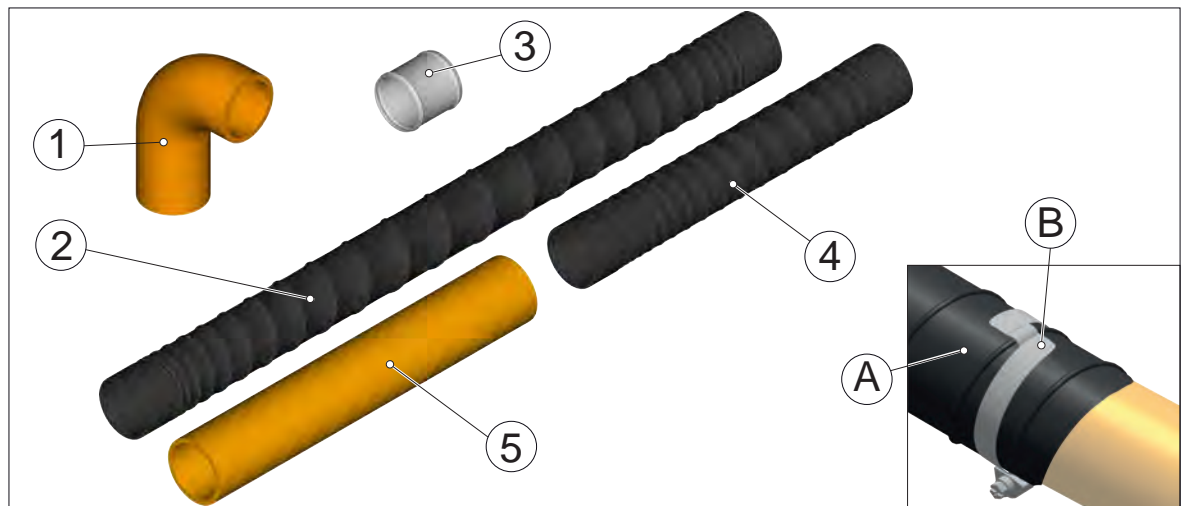

1	Hose elbow 90°
2	Flexible hose piece, cannot be shortened
3	Connecting sleeve
4	Flexible hose piece, cannot be shortened
5	Rigid hose piece, can be shortened

For radii greater than 45°, make sure the radius is as large as possible to prevent the boot from chafing the pipe. If a large radius cannot be realized, it is also possible to use an intermediate piece (90° pipe elbow).

If necessary, the air supply line must be supported, depending on the length, with suitable fasteners in order to avoid damage to the intake system.

NOTICE

If the spiral insert of the hose (A) goes all the way through, a simple hose clamp cannot be used to create a gas-tight connection. For this reason, such hoses can only be used in combination with a spiral hose clamp (B).

7.7 Engine oil

For information on the max. permissible oil temperature, see section *4.1 Engine information and filling quantities, page 16*. For more information on the oil specification and oil viscosity, see section *4.3 Engine oil, page 17*.

7.8 Electrical system

7.8.1 Cabling

NOTICE



All wiring harnesses and lines behind stationary plug connections must be feature a tension relief mechanism after a maximum distance of 100 mm.

NOTICE



All wiring harnesses must be laid in such a way that their properties are not endangered. Note the following criteria here:

- Protection against external influences, e.g., high temperatures, chemical substances, (spray) water etc.
- Protection against motor vibrations, shocks, direct pressure on cables, sharp edges and thus against mechanical damage to the cables.
- Compliance with permissible bending radii and tensile forces.

NOTICE



Line ends that are not connected to a connector (open wire) must be insulated against short circuits.

Engine wiring harness for electronic speed control

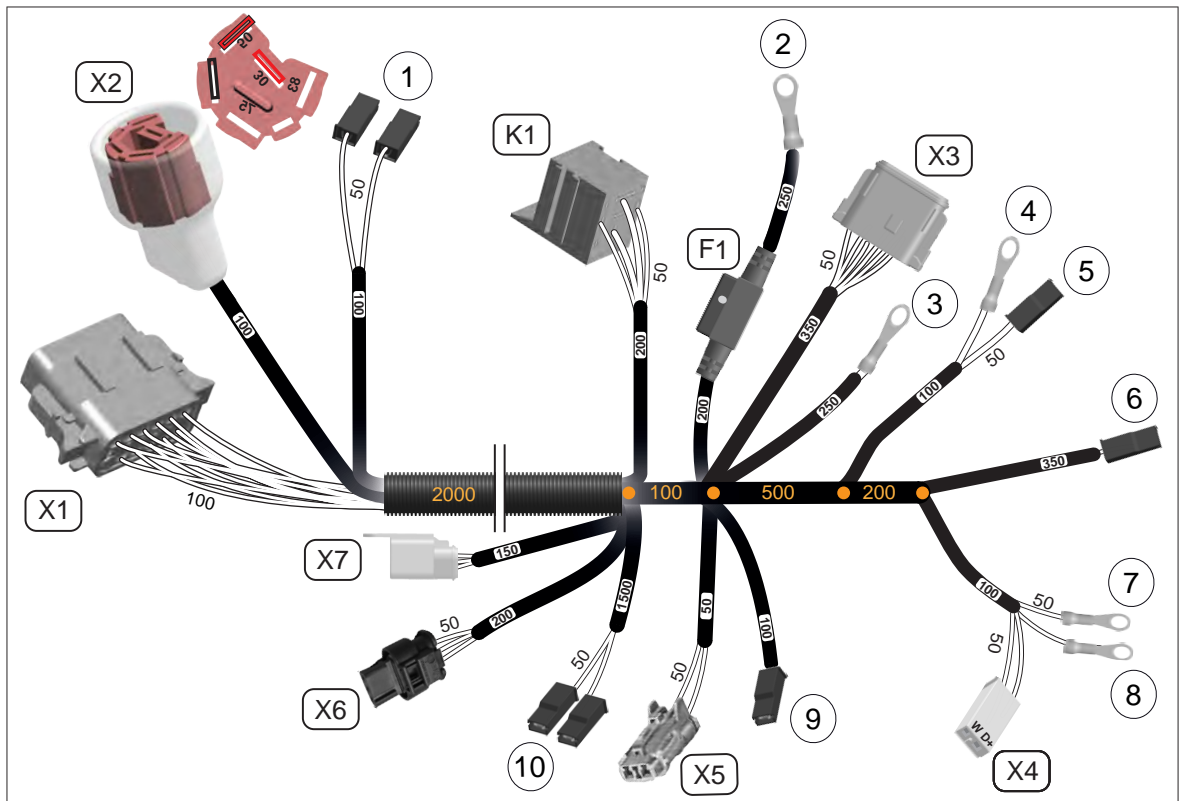

Pin assignment of connectors on the engine wiring harness		Wiring harness, engine	Wiring harness BSZ* (pos. 1)	Designation
Pin no. (X1)	Designation	Line no. (label)	Line no.	Connector/position no.
	T. 30, B+	1		X2 / T. 30
1	Ground / GND	0	0	Pos. 3
2	T. 15	15/24		X2 / T. 15
3	Voltage supply (electronic governor)	7		X3 / Pos. 10
4	Alternator governor (charge control)	2		X4 / T. D+
5	Oil pressure switch	4		Pos. 9
6	Coolant temperature switch	5		Pos. 6
7	-	-		-
8	Pre-heating	13 / 6		K1 / Pos. 2
9	BSZ*		BSZ*	Pos. 1
10	-	-		-
11	Alternator governor (speed sensor)	22		X4, T. W
12	T. 50	3 / 27		X2 / T. 50

BSZ* = operating hours counter / ZSS = ignition start switch (X2)

Engine wiring harness for mechanical speed control

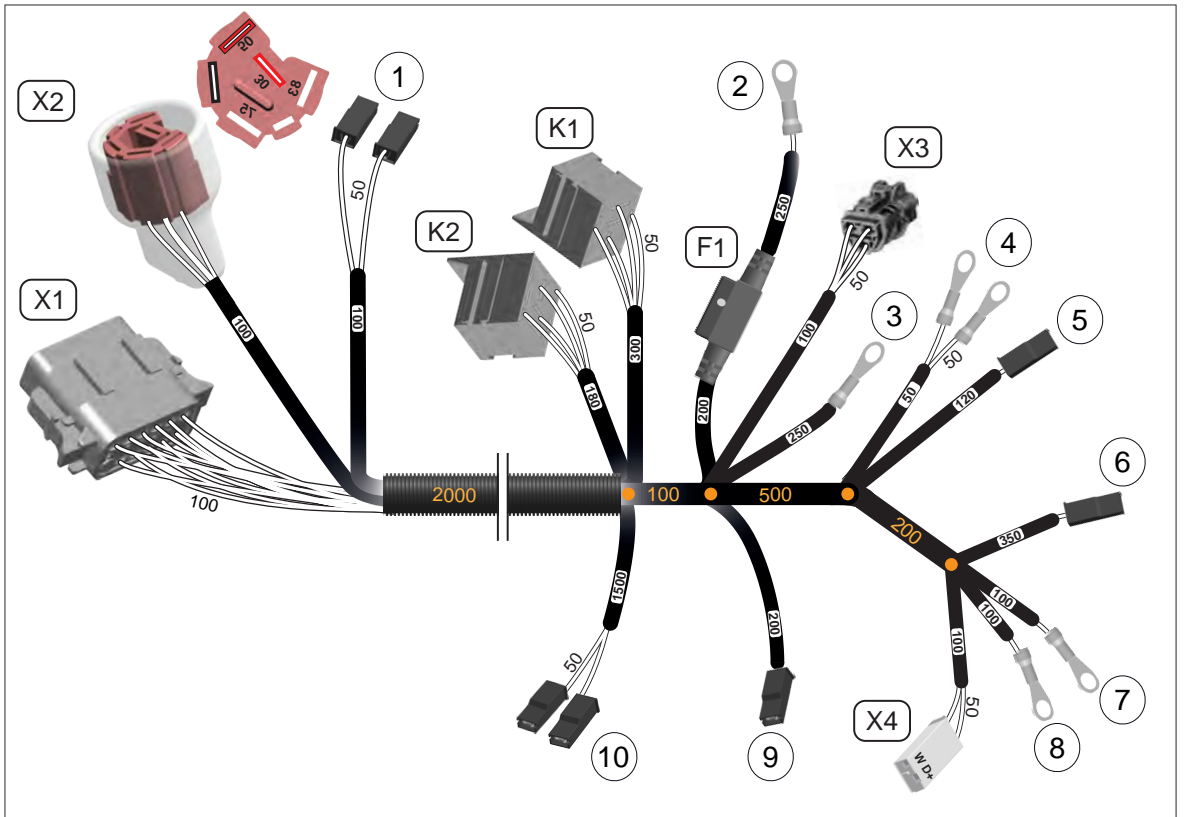

Pin assignment of connectors on the engine wiring harness		Wiring harness, engine	Wiring harness BSZ* (pos. 1)	Designation
Pin no. (X1)	Designation	Line no.	Line no.	Connector/pos. no.
	T. 30, B+	1		X2 / 30
1	Ground / GND	0	0	Pos. 3
2	T. 15	15 / 24		X2 / T.15
3	Holding winding (stop magnet)	7		X3 / Pos. 10
4	Alternator governor (charge control)	2		X4 / T. D+
5	Oil pressure switch	4		Pos. 9
6	Coolant temperature switch	5		Pos. 6
7	-	-		-
8	Pre-heating	13 / 6		K1 / Pos. 2
9	BSZ+		BSZ	Pos. 1
10	Pull-in winding (stop magnet)	18		K2 / X3
11	Speed signal	22		X4 / T. W
12	T. 50	3 / 27		X2 / T. 50

*BSZ = operating hours counter / ZSS = ignition switch (X2)

7.8.2 Engine monitoring

Connection of engine wiring harness (board connector X1 and connector to ignition lock X2) on Autoflex instrument box, see 7.8.1 Cabling, page 50.

Instrument box

The external instrument box consists of the following components:

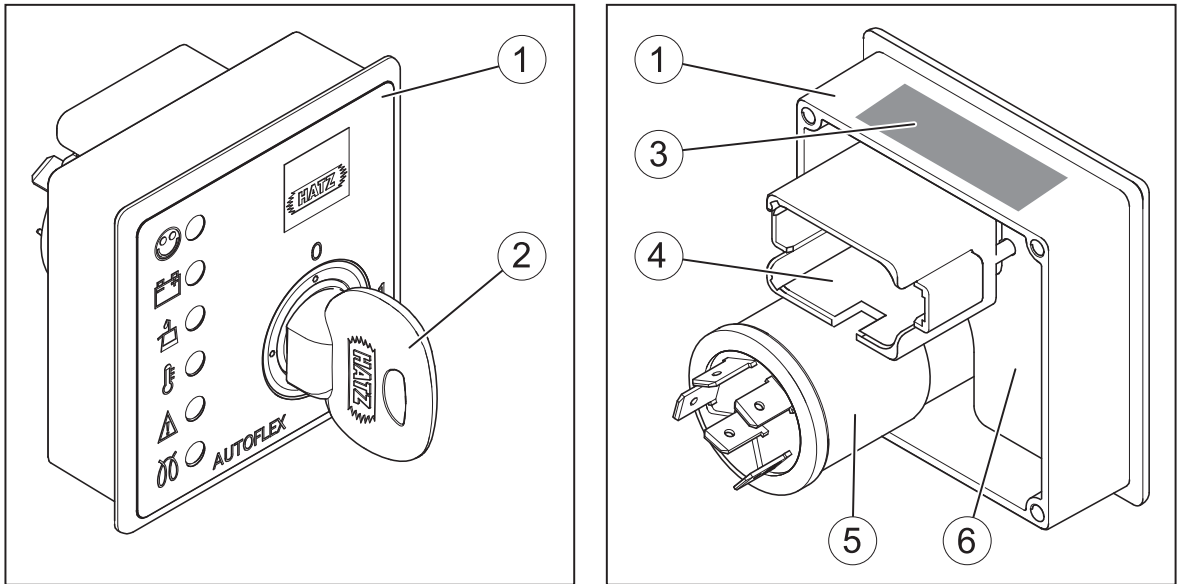

1	Housing
2	Starting key
3	Product label with setup number, production number and production date
4	Board connector
5	Ignition lock
6	Control electronics with integrated indicators (LED)

NOTICE



The instrument boxes are designed to be floating, i.e. there may be no electrical potential present on the housing of the instrument box or on any threaded fasteners.

NOTICE



- The instrument box is programmed before installation and identified by a product label. The setup number or name, production order and production date are printed on the equipment.
- The instrument box is considered to be unprogrammed if it has no adhesive label.
- If the adhesive label is not present or legible when the equipment is being replaced, the engine serial number must be specified.

NOTICE



Protect the ignition lock against dirt and moisture.

- With the starting key pulled out, seal the ignition lock with the protective cap.

7.8.3 Retaining plate for relay

Overview: retaining plate for electronic or mechanical speed control

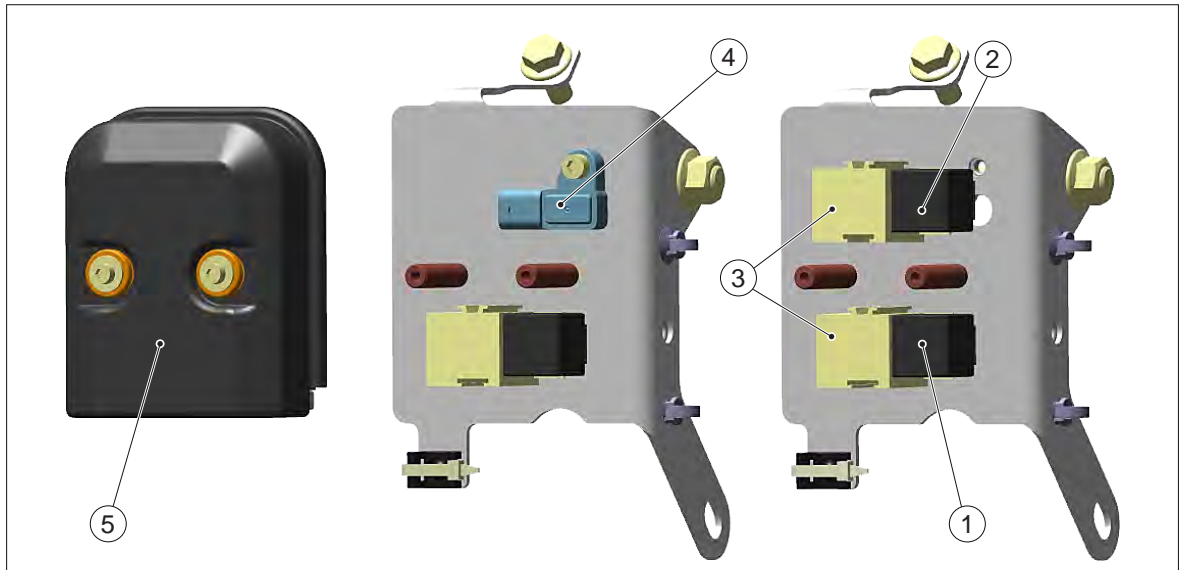

Pos.	Use
1	Relay K1 for glow plug (pre-heating equipment)
2	Relay K2 for pull-in winding (stop magnet) (only for engine specification with mechanical speed control)
3	Plug base, relay K1, K2
4	Ambient pressure sensor (only for engine specification with electronic speed control)
5	Cover

NOTICE



- **Connection and wiring plans** can be viewed at www.hatz.com/docu after entering the engine serial number located on the type plate directly on the engine.
- Liability cannot be accepted **for electrical equipment** that is not designed according to HATZ wiring diagrams.

7.8.4 Battery







DANGER



Danger to life, danger of injury or danger of property damage due to incorrect use of batteries.

- Do not place tools or other metal objects on the battery.
- Before performing work on the electrical equipment, always disconnect the negative battery terminal.
- Never swap the positive (+) and negative (-) battery terminals.
- When installing the battery, first connect the **positive cable** and then the **negative cable**.
- When removing the battery, first disconnect the **negative cable** and then the **positive cable**.
- It is imperative to prevent short circuits and mass contact of current carrying cables.
- If faults occur, check the cable connections for good contact.

 DANGER	
	<p>Danger of explosion from flammable substances.</p> <p>There is a danger of explosion from flammable gases.</p> <ul style="list-style-type: none">▪ Keep batteries away from open flames and incendiary sparks.▪ Do not smoke when working with batteries.
 CAUTION	
	<p>Danger of chemical burns</p> <p>Chemical burns can occur when using batteries for the electrical operation.</p> <ul style="list-style-type: none">▪ Protect your eyes, skin, and clothing from corrosive battery acid.▪ Immediately rinse areas affected by splashed acid with clear water and consult a physician if necessary.

Temperature limits of normal batteries:

- From approx. +60 °C, the self-discharge increases significantly and the service life decreases significantly.
- From approx. -22 °C, half-charged batteries can freeze. A frozen battery must be thawed prior to charging.
- Fully charged batteries have a freezing threshold of approx. -60 °C.

Conclusions concerning the charge state of a battery are possible from measuring the voltage when loaded (min. 1 A). A discharged battery has the rated voltage at the terminals when unloaded!

7.8.5 Battery recommendation

Engine type	3F30, 3F35E	3F45, 3F45E	4F45, 4F45E
Starter	12 V–1.7 kW	12 V–1.7 kW	12 V–2.0 kW
Recommended battery capacity	60 AH	65 AH	80 AH
Low-temperature test current [CCA]	622 A	622 A	651 A
Min. battery size (CCA)	500	500	600

NOTICE



The required battery capacity may deviate, depending on the installation case (e.g., resistances in the hydraulic system).

NOTICE



In the case of lead batteries, a self-discharge of approx. 5% of the total capacity per month must be taken into account.

7.8.6 Battery compartment

The positioning must be verified by temperature measurements.

NOTICE



- The max. ambient temperature of the batteries is +60 °C
- Installation of the battery easily accessible for maintenance work
- Secure the battery mount against inherent movement
- Ventilation of the battery installation compartment
- Mounting of electrical switches in the vicinity of the battery is not permitted due to sparking and the potential explosion hazard.

7.8.7 Starter

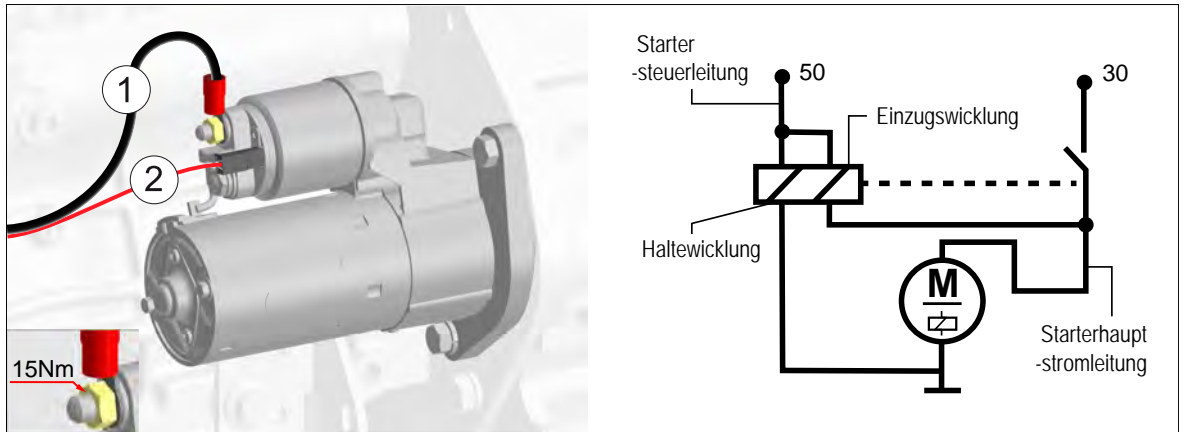

Using the ignition switch, the pull-in winding and holding winding of the starter solenoid (terminal 50) (pos. 2) are switched on via the starter relay (short-term max. 50 A in the pull-in winding and **10 A** in the holding winding). At the end of the pull-in path (starter pinion engaged in the sprocket), the main starter current is switched on (depending on the starter and condition, approx. 450 to 500 A). The starter motor is now connected directly to the battery by terminal 30 (pos. 1) and the main starter line.

NOTICE



It is recommended to protect the starter terminal 30 (B+ connection) against short circuits (e.g., caused by electrically conductive foreign bodies) with a suitable cover (e.g., rubber protective cover). Short circuits can cause cable fires and damage to other electronic components.

Sizing of the line between the starter and battery



NOTICE



When using a larger battery capacity, the conductor cross section and/or the length of the main starter line must be adapted accordingly to prevent overload or starter damage.

To determine the right line cross section, please contact HATZ service.

7.8.8 Alternator

The power consumption of the engine is an approximate value that depends on multiple conditions (such as temperature, voltage, etc.). Max. permissible **ambient temperature 90 °C**.

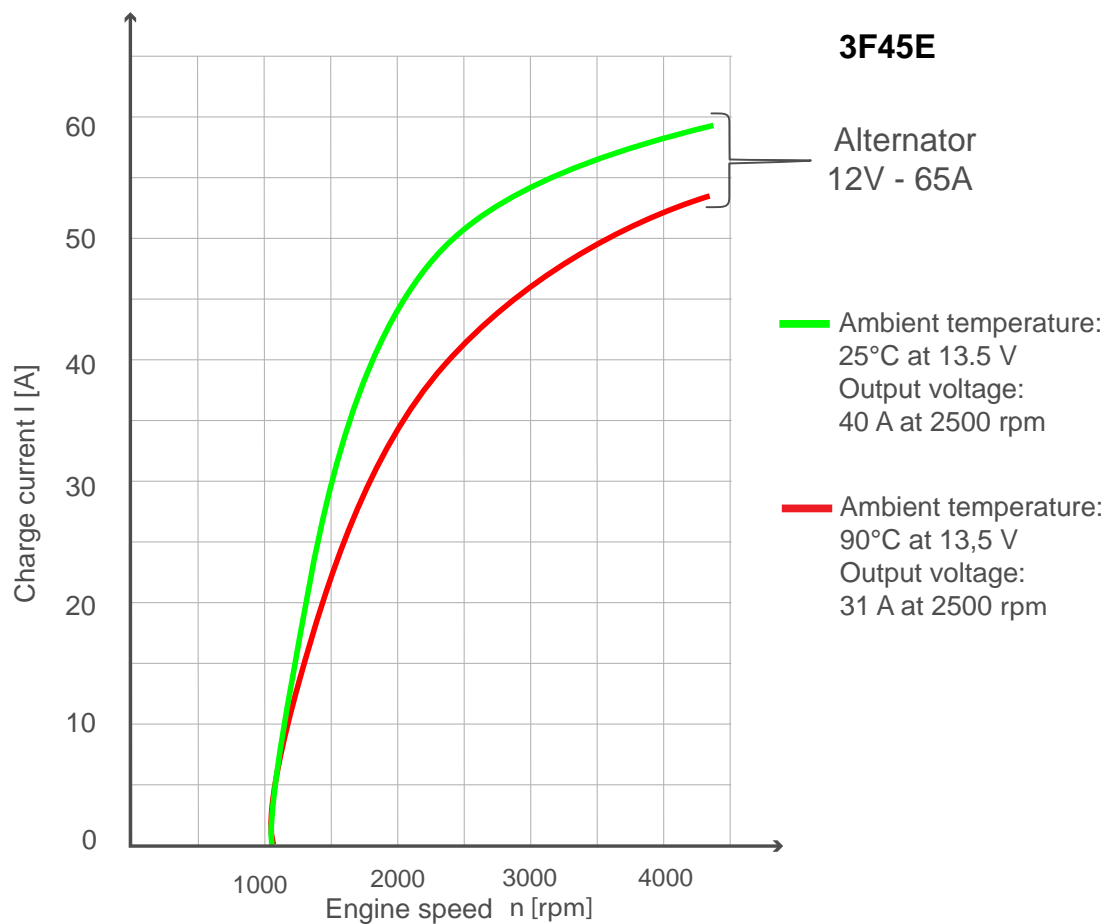

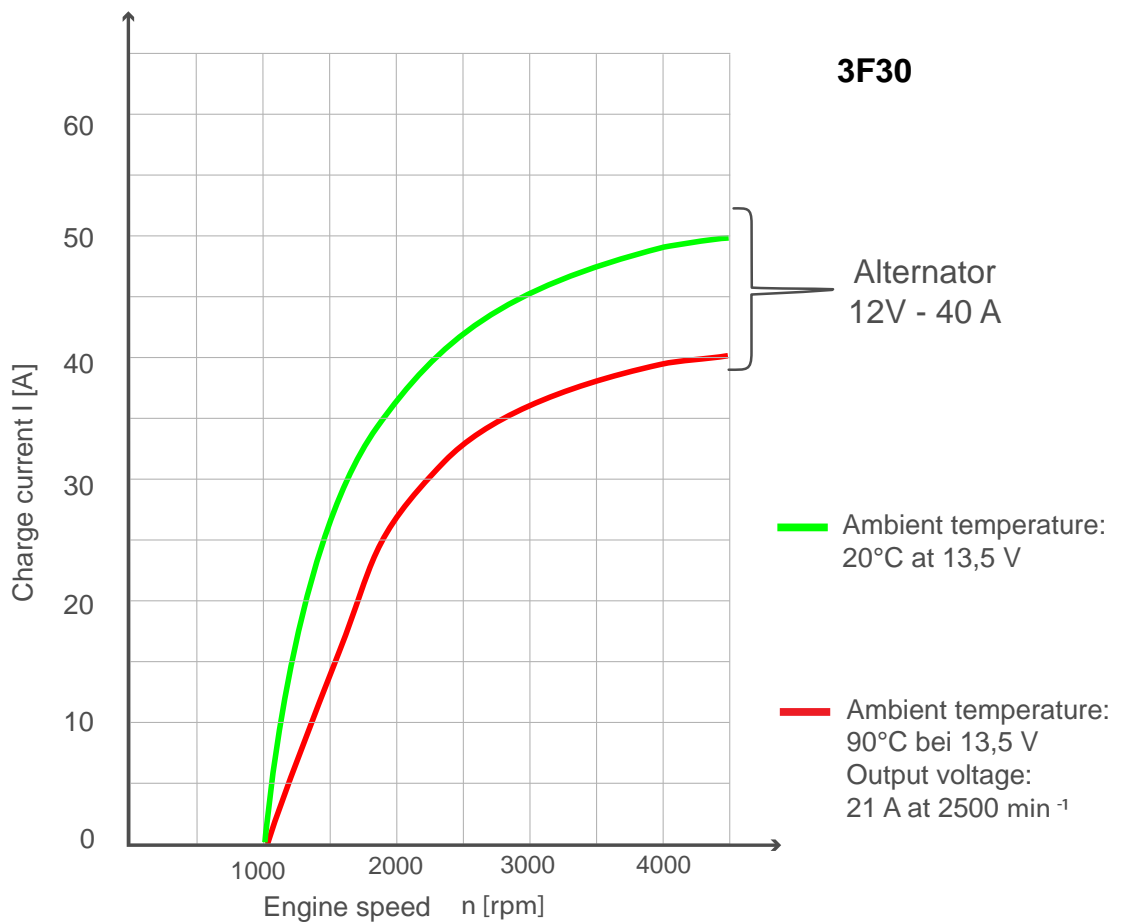
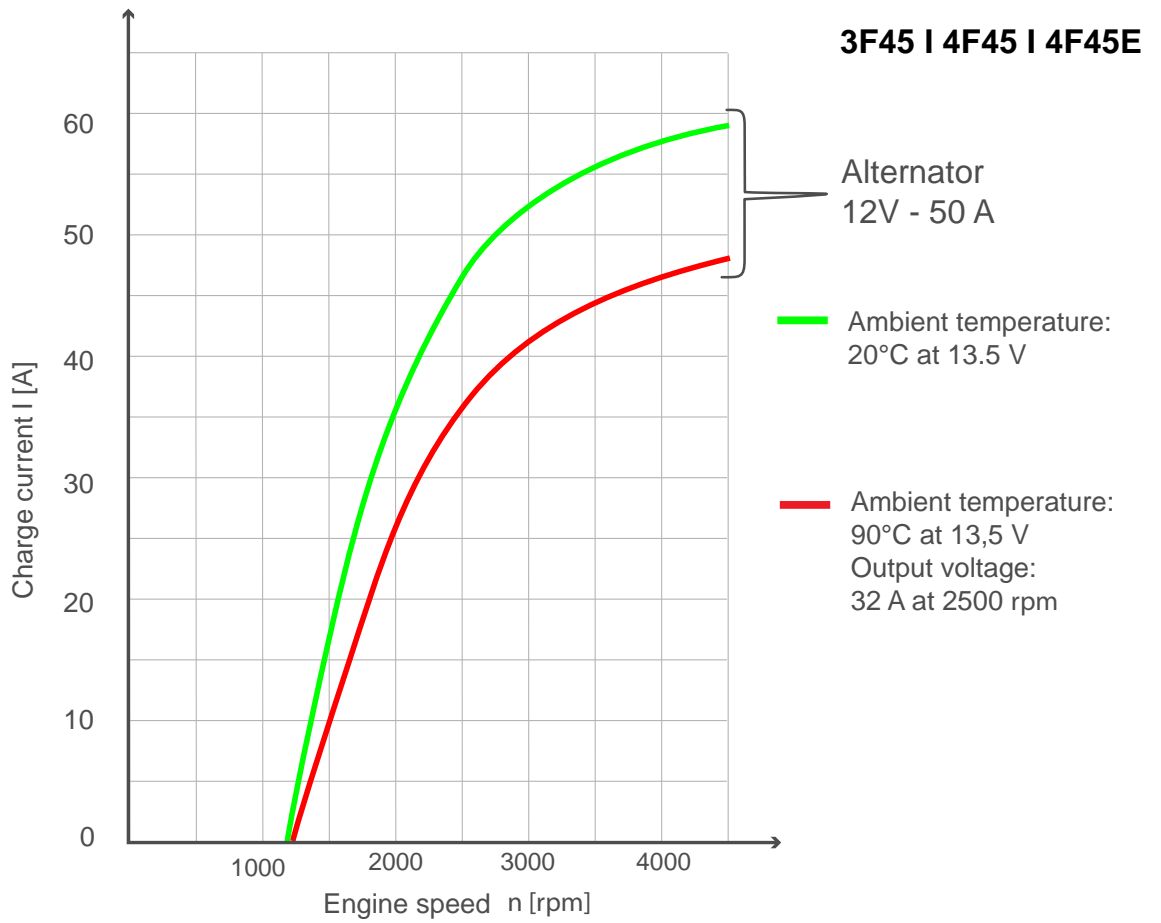

7.9 Power take off

The permissible load on the power take off on the engine **flywheel side** or **timing cover side** can be found below.

7.9.1 Main take off – flywheel side

NOTICE

 Before installing further add-on parts, the preservation wax must be removed from the screw-on surfaces and the surfaces must be cleaned.

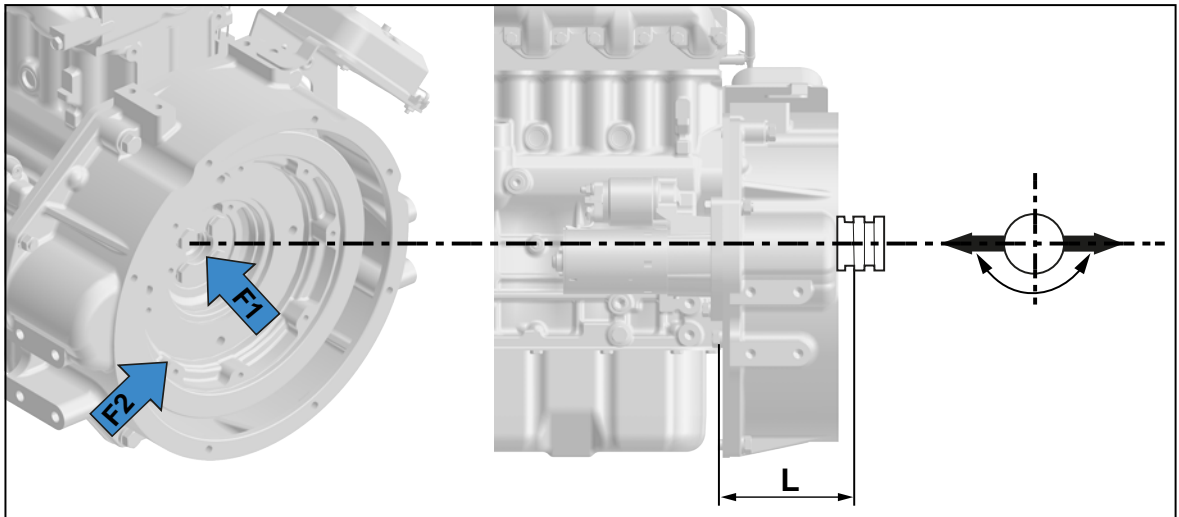

	3F30 (cs / vs)	3F45, 3F45E, 4F45, 4F45E (cs)
Axial (F1)	980 N intermittent (e.g. gearshift clutch) 490 N continuous operation	1080 N continuous operation
Radial (F2)	1470 N at max. 100 mm distance (L) from the crankcase flange.	1960 N at max. 120 mm distance (L) from the crankcase flange.
*Max. perm. mass moment of inertia	2.45 kgf*cm*s ²	

7.9.2 Main power take off – timing cover side (belt drive)

The engine can optionally be equipped with a second belt drive on the timing cover side – mounted coaxially downstream of the first belt pulley – for the power take off of another machine.

For detailed installation instructions, contact **Hatz Motorenfabrik**.

NOTICE

 Before installing a second belt pulley, the centering and contact areas of the engine belt pulley must be freed of paint remnants and cleaned. This is necessary to be able to precisely center and optimally mount the second belt pulley. This ensures that the unit can be securely fastened and that power transmission is even and reliable.

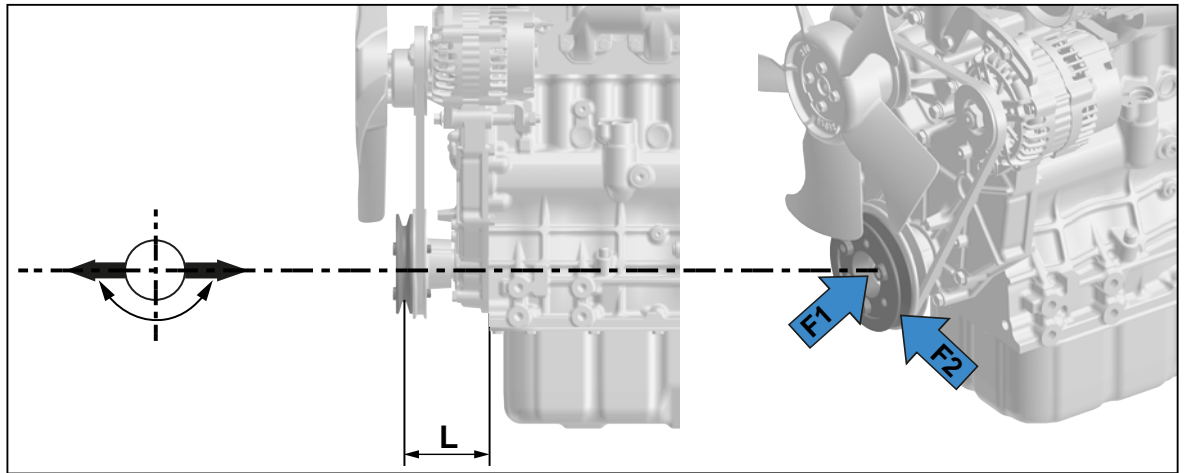

	3F30 (cs / vs)	3F45, 3F45E, 4F45, 4F45E (cs)
Radial (F2)	680 N at max. 120 mm distance (L) from the crankcase flange. Max. permissible torque 30 Nm.	1470 N at max. 120 mm distance (L) from the crankcase flange.

When using an additional belt track, an 7.2.1 *ergänzende Aussteifung der Motorfüße*, page 25 is required on the engine-side cooler unit.

7.9.3 Torsion momentum calculation

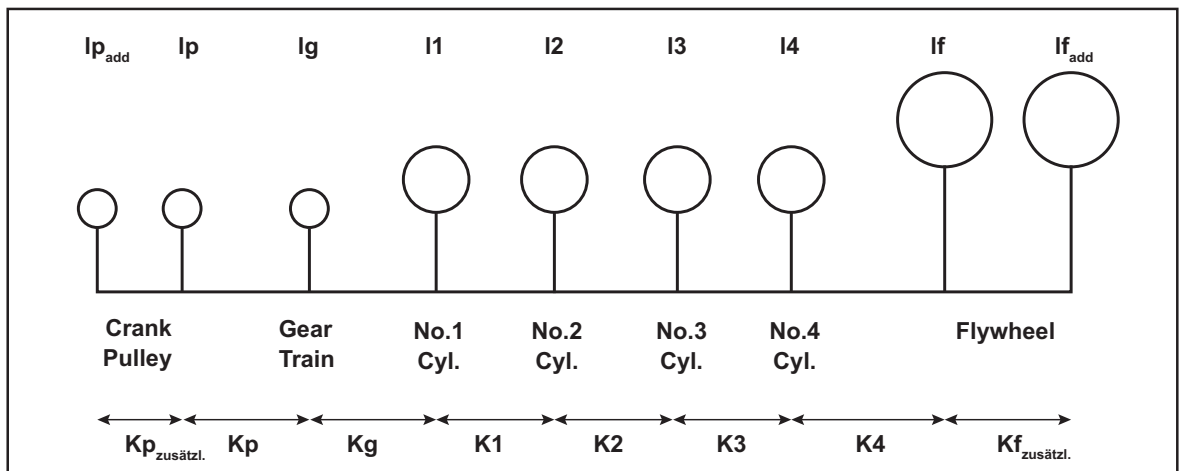

		3F30	
		cs ¹⁾	vs ²⁾
I (kgf*cm*s ²)	I _{Radd}	-	
	I _R	0.013	On request
	I _G	0.008	-
	I ₁	0.043	-
	I ₂	0.040	-
	I ₃	0.043	-
	I ₄	-	-
	I _S	2.68	-
	I _{Sadd}	2.45	-

N x10 ⁶ (kgf*cm/rad)	K_{Radd}	-	-
	K_R	1.01	-
	K_G	3.87	-
	K1	3.09	
	K2	3.08	
	K3	4.36	
	K4	-	
	K_{sadd}	1.00 ³⁾ , 10.00 ⁴⁾	

¹⁾ With a heavy flywheel, ²⁾ With a standard flywheel,

³⁾ 1×10^6 → no harmful resonance point present under 1485 rpm. (No problems with the tension level of the crankshaft.)

⁴⁾ 10×10^6 → no harmful resonance point present under 1485 rpm.

7.9.4 7.5" flywheel with connection housing SAE5

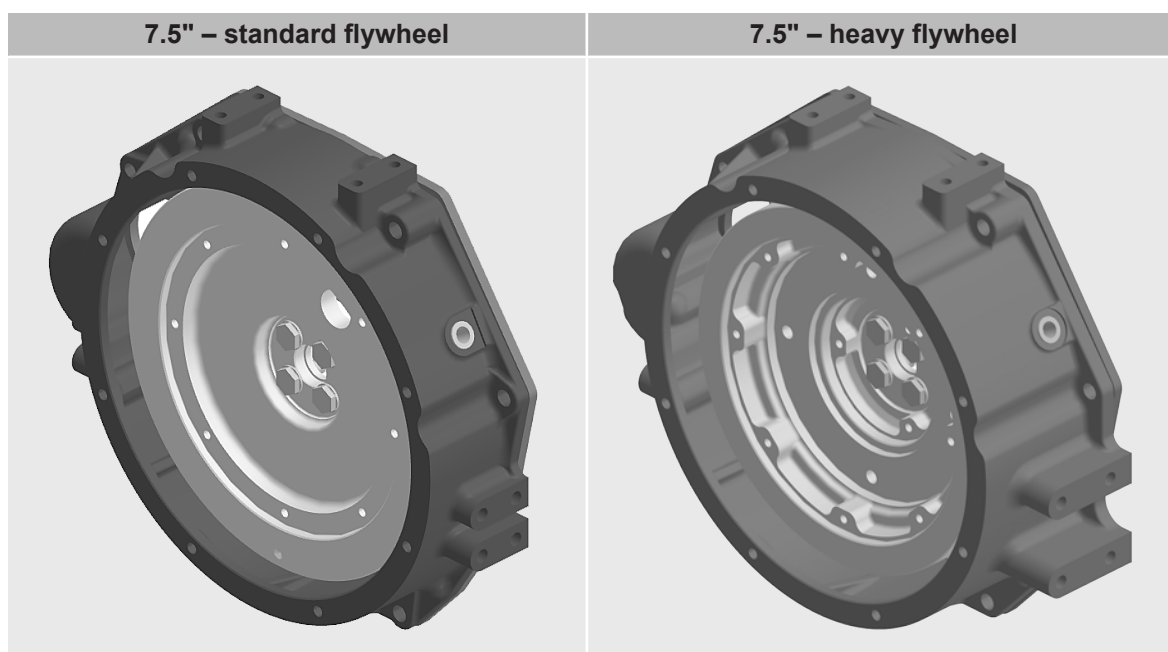

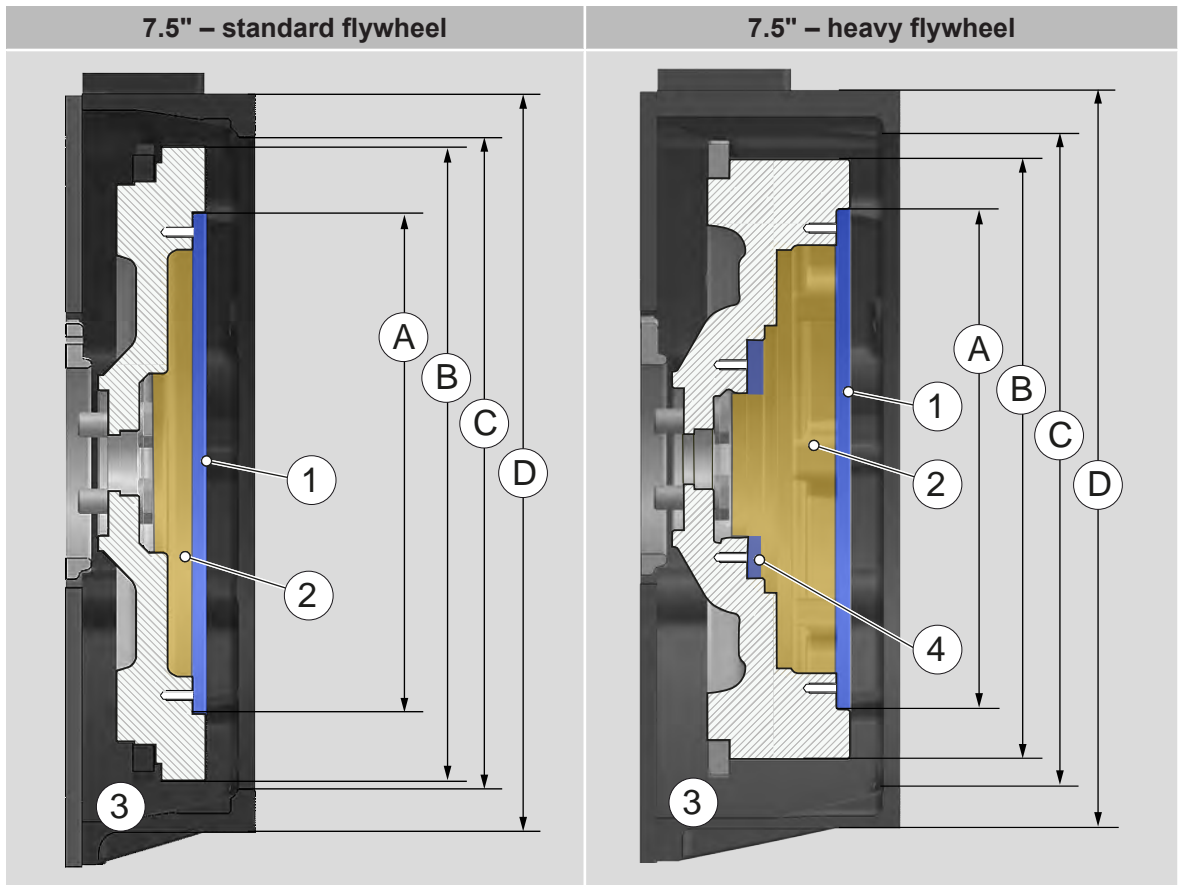

- 1 Coupling diameter
- 2 Indentation
- 3 Connection housing SAE5
- 4 Additional fitting dimensions for heavy flywheel:
202H7; 4 x M12x1.25
116H7; 3 x M8x1.25

Flywheel	A		B		C		D	
	mm	inch	mm	inch	mm	inch	mm	inch
Standard	241.3	9.5	306		314.3	12.375	355.6	14
Heavy	241.3	9.5	290		314.3	12.375	355.6	14

7.9.5 Flywheel 6.5" with connection housing SAE5

6.5" - standard flywheel		6.5" - heavy flywheel						
1	Coupling diameter							
2	Indentation							
3	Connection housing SAE5							
4	Additional fitting dimensions for heavy 6.5" flywheel: 116H7; 3 x M8x1.25							
	A		B		C		D	
Flywheel	mm	inch	mm	inch	mm	inch	mm	inch
Standard	215.9	8.5	292		314.3	12.375	355.6	14
Heavy	215.9	8.5	292		314.3	12.375	355.6	14

7.10 General limits of use

7.10.1 Cold start capability

The following specifications are valid up to an altitude of approx. 1460 m above sea level. At higher altitudes, the cold-start capability deteriorates compared to these values.

Cold start with 12-V equipment	-15 °C
--------------------------------	--------

The driven machines should now draw a load during the starting process. If this cannot be guaranteed, e.g., in hydraulic systems, an increase in the minimum cold starting temperature can be expected. This cold start limit temperature must always be determined experimentally, depending on the application and use case.

7.10.2 Extreme conditions

The engine is usually not used at the standard reference point of the **performance standard ISO 3046-1**, (+ 25 °C, 100 m above sea level, 30 % rel. humidity), but in places with **higher altitude and higher/lower temperatures, usually also with higher relative humidity**.

Temperature increases caused by sunlight under a cowling must also be considered.

Due to climatic conditions that differ from the standard reference location (altitude, air pressure, temperature, humidity, contamination), the load capacity of the engine leads to power reductions or system adjustments for extreme operating conditions.

Therefore, it is necessary to consult the **Motorenfabrik Hatz main plant** in order to best match the system to the application.

7.11 Maintenance

7.11.1 Accessibility of service points

When installing the engine, it must be ensured that all service points are readily accessible to be able to perform all necessary maintenance work; see section *10.2.1 Maintenance plan, page 80*.

All maintenance labels must be affixed to the engine and/or machine so that they are clearly legible.

Service points – operating side

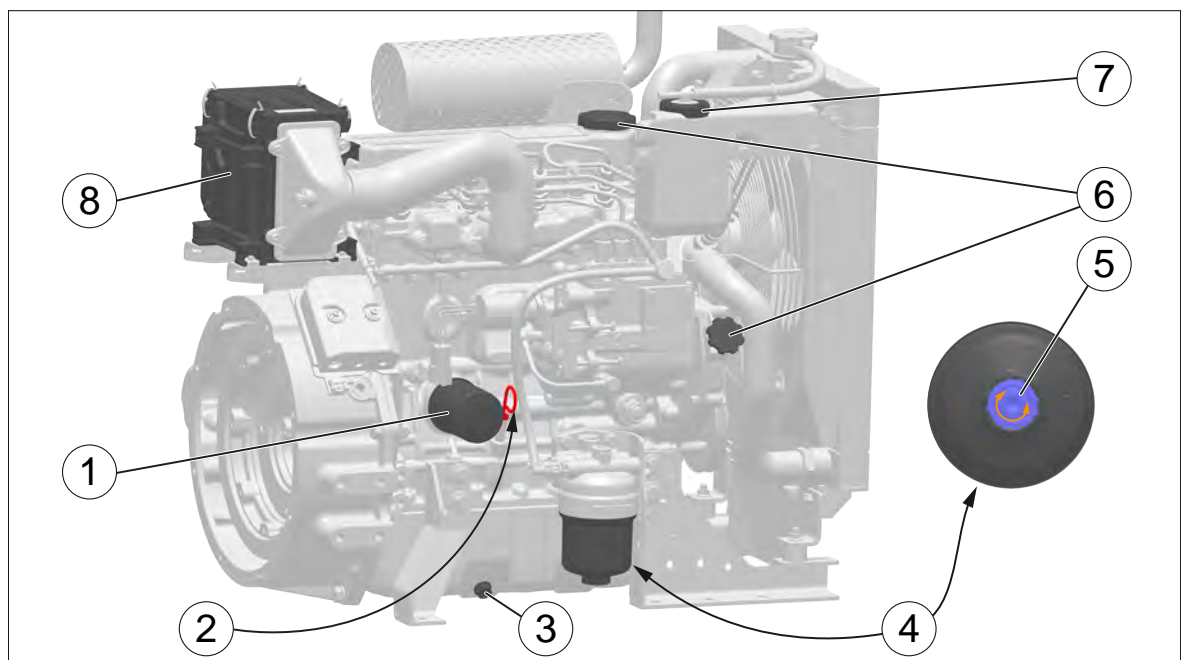

1	Oil filter
2	Dipstick
3	Oil drain screw
4	Main fuel filter
5	Water separator
6	Oil filler plug (top, bottom)
7	Screw plug on the overflow container
8	Air filter (optional)

NOTICE



Tightening torque, see section 7.1.1 *Torques and screw classification*, page 24.

7.12 Contact protection for machine safety

7.12.1 Contact guard

It is the responsibility of the manufacturer to heed and comply with the safety rules that apply to an engine in a finished machine.

The following chapter shows which contact protective devices are available from HATZ.

The following overview shows the hot surfaces (exhaust manifold etc.) and rotating parts (flywheel, fan, poly v belt etc.). There is an increased risk of injury here.

It is the duty of the machine manufacturer to ensure that all safety precautions (e.g., contact guard at the exhaust manifold) are taken for the whole machine so that any injury from hot surfaces and rotating parts is ruled out.

7.12.2 Hot surfaces and rotating parts

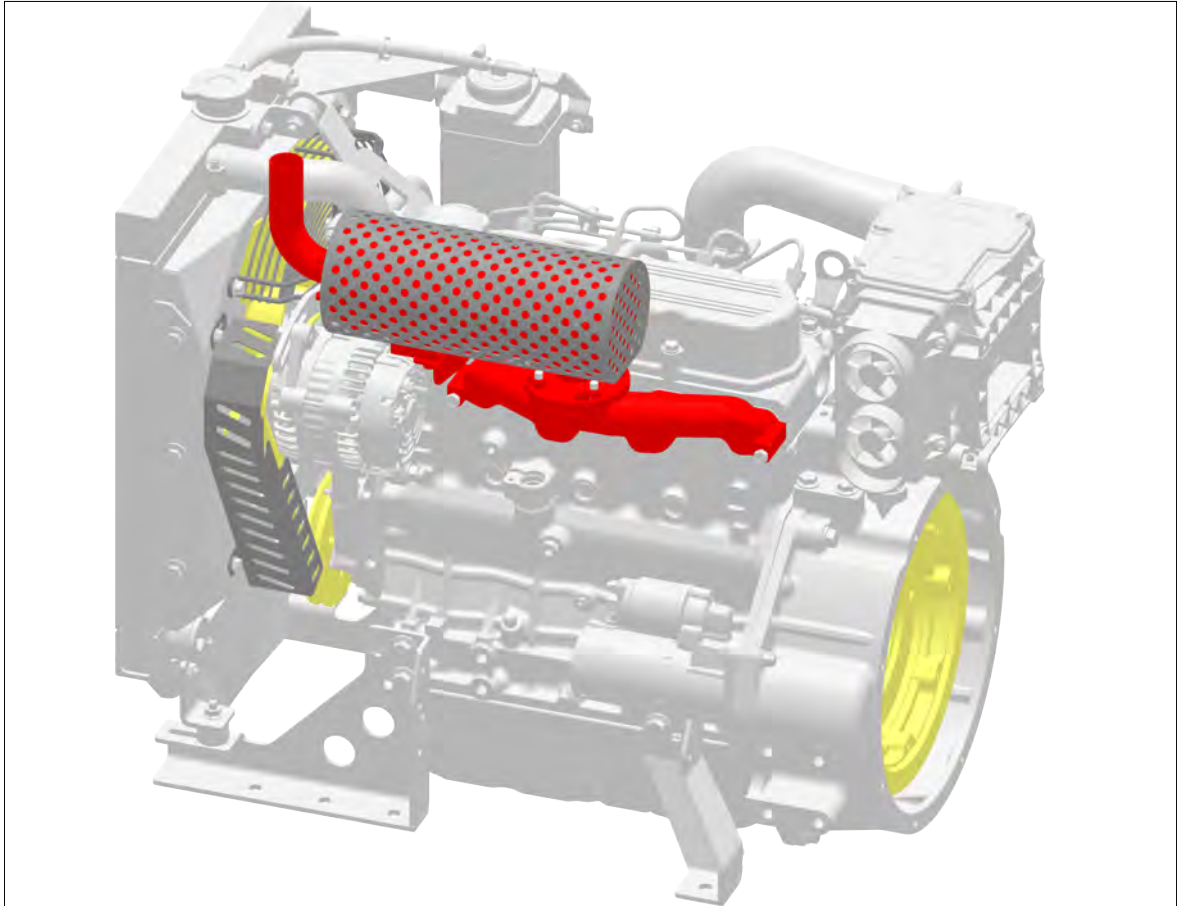

Hot surfaces:

Exhaust manifold and silencer with contact guard

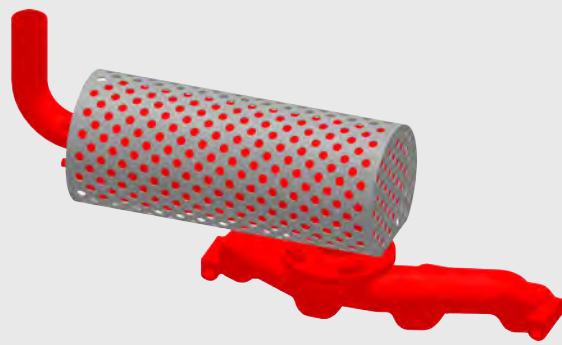

Rotating parts:

V-belt drive (fan, V-belt, alternator) with contact guard

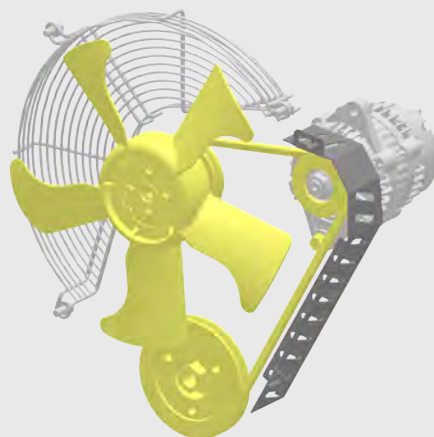

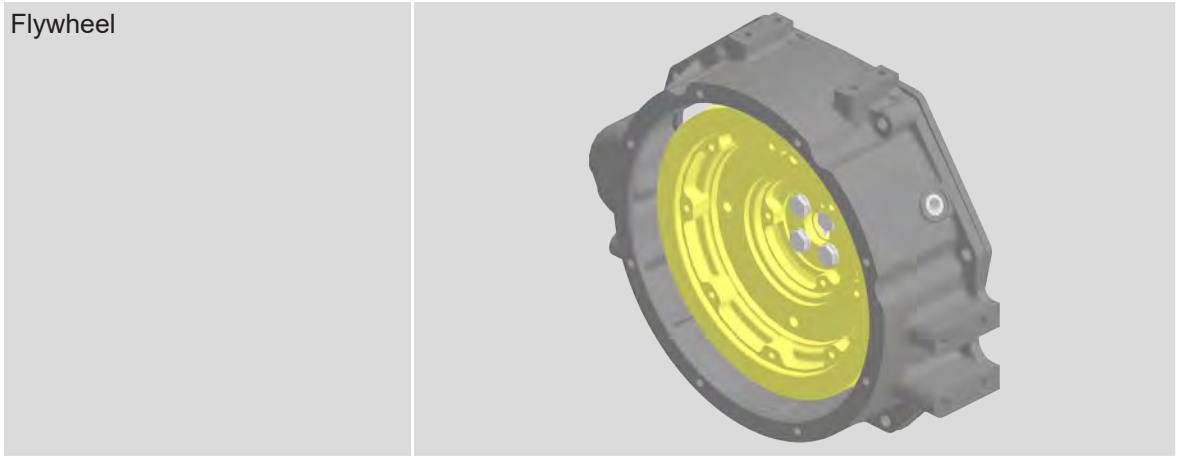

Flywheel



8 Commissioning

8.1 Preparations for commissioning

- Check the delivered parts for completeness, damage, and other noticeable issues.
- Ensure that the setup location is adequately ventilated.

 DANGER	
	<p>Danger to life from inhaling exhaust gases.</p> <p>Toxic engine exhaust gases can lead to loss of consciousness, and even death, in closed-off and poorly ventilated rooms.</p> <ul style="list-style-type: none"> ▪ Never operate the machine in closed-off or poorly ventilated rooms. ▪ Do not breathe in the exhaust gases.

8.2 Filling engine oil (first filling)

Engines are normally delivered without an engine oil filling.

Safety note

CAUTION	
	<p>Danger of later engine damage.</p> <ul style="list-style-type: none"> ▪ Operating the engine with an oil level below the min. mark or above the max. mark can lead to engine damage. ▪ When checking the oil level, the engine must be horizontal and have been switched off for a few minutes.

Overview

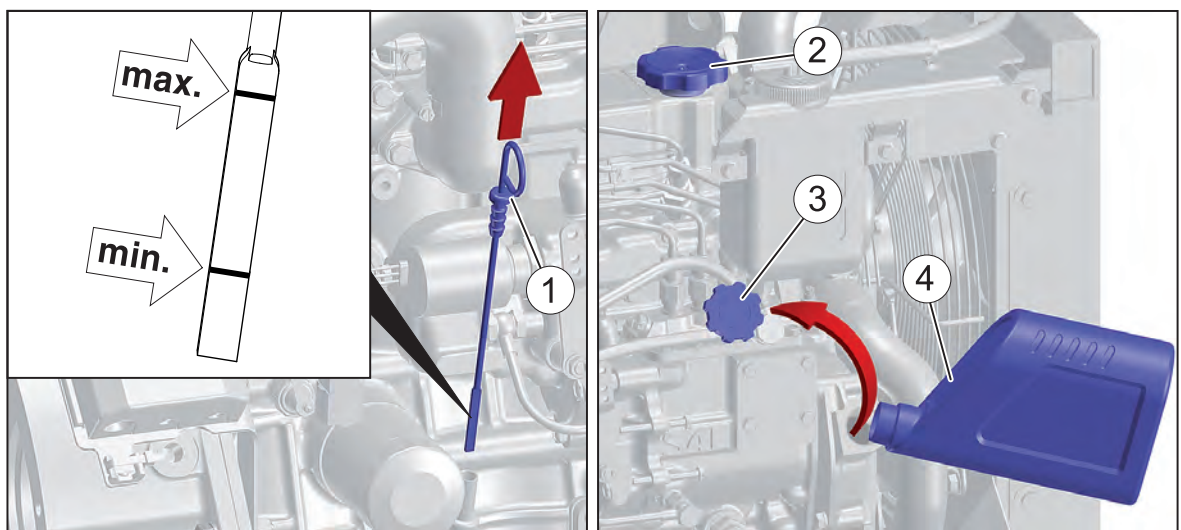

1	Dipstick
2	Oil filler plug, top
3	Oil filler plug, bottom
4	Oil refilling container

Procedure



Step	Activity
1	Pull out the dipstick (1) and wipe it off with a clean towel.
2	Unscrew the oil filler plug (2) or (3).

Step	Activity
3	Fill with engine oil. For the specification and viscosity, see section 4.3 <i>Engine oil</i> , page 17. For the filling quantity, see section 4.1 <i>Engine information and filling quantities</i> , page 16.
4	Reinsert the dipstick.
5	Pull out the dipstick and check the oil level.
6	If necessary, add engine oil to the max. mark.
7	Reinsert the dipstick.
8	Screw in the oil filler plug.

8.3 Filling the cooling system

Safety notes

⚠ CAUTION

Danger of burns.

There is a danger of burns when working on a hot cooling system. The cooling system is pressurized when the engine is hot.

- Let the engine cool.
- Wear safety gloves.

CAUTION

Danger of later engine damage.

- Operating the engine with a coolant level below the **MIN.** mark can lead to engine damage.
- When checking the coolant level, the engine must be horizontal and switched off.

Overview

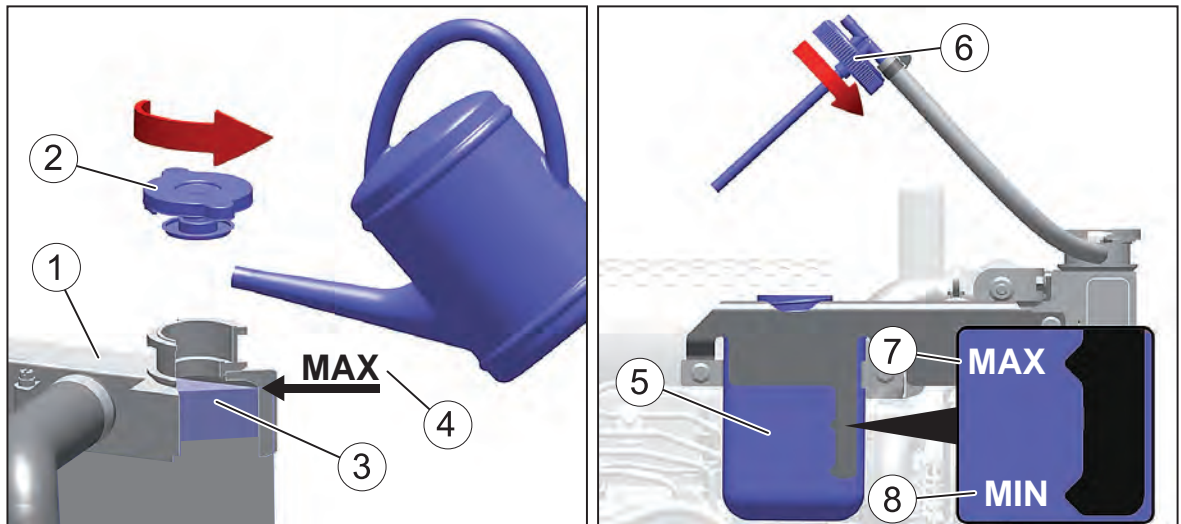

1	Cooler
2	Cooler cap
3	Coolant
4	MAX - Maximum coolant level in cooler
5	Overflow container
6	Screw plug on the overflow container
7	MAX - Maximum coolant level in overflow container

8	MIN - Minimum coolant level in overflow container
---	--

Procedure

Step	Activity
1	Open and remove the cooler cap (2).
2	Top up the coolant to the lower edge (4) of the filler neck. For preparation of the coolant, see section 4.4 <i>Coolant</i> , page 17.
3	Tighten the cooler cap (2) all the way by hand.
4	Open and remove the screw plug (6).
5	Top up coolant to the MAX mark (7).
6	Tighten the screw plug (6) by hand.
4	Start the engine (see chapter 9 <i>Operation and use</i> , page 72).
5	Warm up the engine until the coolant has reached a temperature of approx. 80 °C. Above this temperature the coolant is pumped through the entire cooling system and forces out remaining air bubbles.
6	Switch off the engine and let it cool down completely (see chapter 9 <i>Operation and use</i> , page 72).
7	Check the coolant level again. The coolant must be seen between the MIN and MAX mark; for a warm engine the level can also be slightly above the MAX mark.
8	Check the cooling system for leaks, retighten the hose clips if necessary (see section 10.2.4 <i>Checking the cooling system</i> , page 83).

8.4 Venting the fuel system

Requirements

The fuel system must be bled in the following situations:

- At first filling of the fuel tank
- After the fuel prefilter or main fuel filter is replaced
- Engine shuts down due to empty fuel tank

Overview

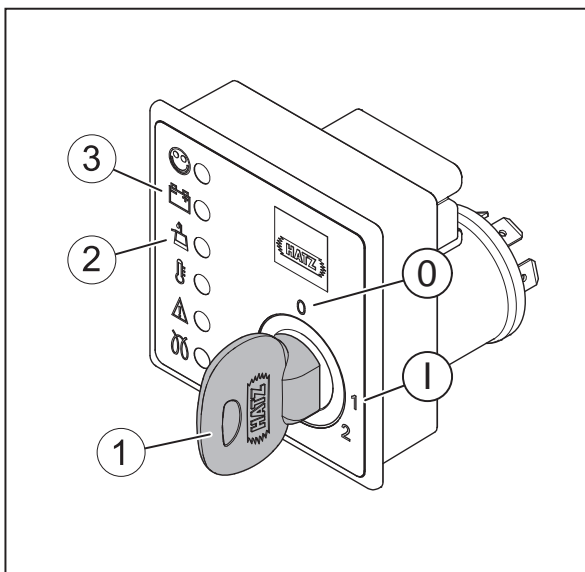

1	Starting key
2	Oil pressure indicator
3	Charge control



Ignition lock	
0	Off
I	Operation

Procedure

Step	Activity
1	Insert the starting key all the way and turn to position "I". The oil pressure indicator (2) and charge control (3) light up.
2	Leave the starting key at position "I" until you hear the electric fuel feed pump switch off (usually after approx. 10 seconds).
3	Turn the starting key back to position "0". <i>Note:</i> Carry out steps 2 and 3 several times to press the air out of the fuel system.
4	Start the engine, see section 9 <i>Operation and use</i> , page 72.

9 Operation and use

9.1 Safety notes

NOTICE	
	<p>Comply with the safety chapter! Follow the basic safety instructions in chapter 3 <i>Safety</i>, page 7.</p>
WARNING	
	<p>Danger of injury from damage and defects on the machine.</p> <ul style="list-style-type: none"> ▪ Do not take the machine into service if damage has been localized and identified. ▪ Replace defective components.
WARNING	
	<p>Danger of injury from failure to follow the operating instructions and from performing unauthorized tasks on the machine.</p> <ul style="list-style-type: none"> ▪ Define the responsibilities of the personnel taking the machine into service. ▪ Replace defective machine parts immediately. ▪ Check the installation conditions when the machine is first taken into service and after the machine has been inactive for a lengthy period.
CAUTION	
	<p>Danger of engine damage from low load operation.</p> <p>Operating the engine at no load or at very low load for an extended period can impair the running characteristics of the engine.</p> <ul style="list-style-type: none"> ▪ Make sure that the engine load is at least 15 %. ▪ Before switching off the engine following low load operation, briefly operate it at a considerably higher load.

9.2 Performing tests

Before starting

Before starting the engine, several tests need to be performed to ensure the machine is working properly.



Procedure

Step	Test
1	The machine is standing securely and on a level surface.
2	The installation location is adequately ventilated.
3	There is a sufficient amount of fuel in the fuel tank (see chapter 9.6 <i>Refueling</i> , page 78).
4	There is a sufficient amount of engine oil in the engine housing (see chapter 9.5 <i>Checking the oil level</i> , page 76).
5	There is a sufficient amount of coolant in the expansion tank (see chapter 10.2.4 <i>Checking the cooling system</i> , page 83).
6	Cooler and cooler hoses are free from leaks (see chapter 10.2.4 <i>Checking the cooling system</i> , page 83).
7	No persons are located in the danger zone of the engine or machine.
8	All safety equipment is in place.

9.3 Starting the engine

If possible, separate the engine from the machine being driven by uncoupling it. Always switch the machine into idle mode.

Safety notes

 DANGER	
	<p>Danger to life from inhaling exhaust gases.</p> <p>Toxic engine exhaust gases can lead to loss of consciousness, and even death, in closed-off and poorly ventilated rooms.</p> <ul style="list-style-type: none"> ▪ Never operate the machine in closed-off or poorly ventilated rooms. ▪ Do not breathe in the exhaust gases.
CAUTION	
	<p>Danger of engine damage from the use of starting fluid.</p> <ul style="list-style-type: none"> ▪ Engine damage from the use of starting fluid can lead to uncontrolled ignition. ▪ Engine damage from uncontrolled ignition. ▪ Never use starting fluid.
NOTICE	
	<p>See also starting instructions in the documentation for the complete machine.</p>

Overview – HATZ instrument boxes

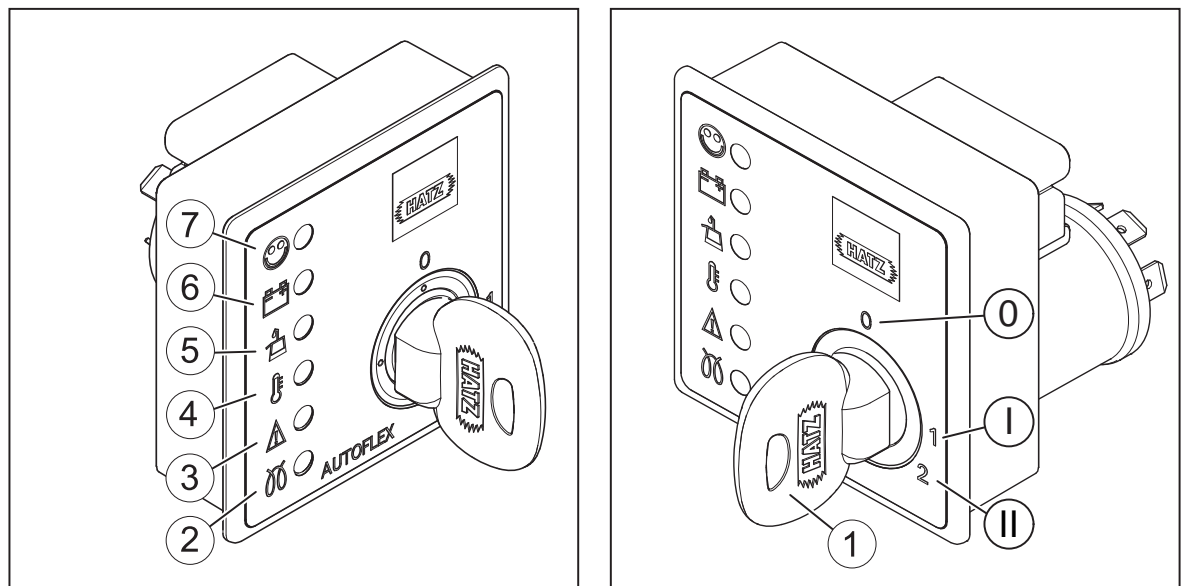







1	Starting key
2	Pre-glow indicator (option)
3	Indicator for special customer functions (see the section "Explanation of symbols")
4	Coolant temperature indicator
5	Oil pressure indicator
6	Charge control
7	Operating indicator

Ignition lock	
0	Off
I	Operation
II	Start

Indicator lamps

The function of all indicators is checked after the starting key is turned to position "I". They light up consecutively from top to bottom. After the test, only the indicators for charge control and oil pressure are lit. If there is a fault, the applicable indicator does not go out after the engine start or it lights up again during operation. If the unit is switched off due to overspeed, all LEDs flash.

Explanation of symbols

Symbol	Meaning
	Operating indicator Lights up during operation when there is no engine fault.
	Charge control Fault in the alternator or alternator charging circuit. The battery is no longer charged. Eliminate the fault immediately.
	Oil pressure indicator Engine oil pressure too low. Danger of engine damage. Stop the engine immediately and check the oil level (see chapter 9.5 <i>Checking the oil level</i> , page 76). Contact the HATZ service if the oil level is correct.
	Coolant temperature indicator Raised coolant temperature. Operate engine at reduced load. Switch off the engine if the indicator does not go off after 5 minutes. For details on troubleshooting, see chap. 11.1 <i>Troubleshooting</i> , page 105.
	Special customer functions (e.g., electrical maintenance switch or stop switch). For further information, see the documentation for the complete machine.
	Pre-glow indicator Lights up at temperatures below 0 °C (depending on the setup). Start the engine after the indicator has gone out.

Procedure – starting the engine

NOTICE	
	<ul style="list-style-type: none"> ▪ Start for max. 10 seconds. If the engine still does not start, the starting procedure can be repeated after waiting at least 60 seconds. After three unsuccessful start attempts, find the cause of the fault (see chap. 11.1 <i>Troubleshooting</i>, page 105). ▪ Turn the starting key to position "0" every time you want to start the engine. ▪ The anti repeat device in the ignition lock makes it impossible for the starter to engage while the engine is running and become damaged.



Step	Activity
1	Depending on the situation, place the speed control lever in either the "1/2" or "Start" position. <i>NOTE:</i> A low speed setting will cause less exhaust smoke when starting.

Step	Activity
2	<p>Insert the starting key all the way and turn to position "I".</p> <p>Depending on the model, the following indicators light up:</p> <ul style="list-style-type: none"> ▪ Pre-glow indicator (2) ▪ Oil pressure indicator (5) ▪ Charge control (6) <p><i>NOTE:</i> When indicator (4) lights up, the coolant temperature is impermissibly high. Do not start the engine; eliminate the cause.</p> <p>When the pre-glow indicator goes out, continue with step 3.</p>
3	Turn the starting key to position "II".
4	<p>As soon as the engine is running, release the starting key.</p> <ul style="list-style-type: none"> ▪ The starting key springs back to position "I" and remains in this position during operation. ▪ The charge control (6) and oil pressure indicator (5) go out. ▪ The operating indicator (7) lights up and signals that there is no engine fault.
5	After starting the engine, allow it to warm up for 5 to 10 minutes at low speed and without load.

NOTICE	
	<ul style="list-style-type: none"> ▪ In case of irregularities, switch off the engine immediately. ▪ Identify the fault and eliminate it. ▪ For details of troubleshooting, see chapter 11.1 <i>Troubleshooting</i>, page 105.

9.4 Switching off the engine

Safety notes

 CAUTION	
	<p>Danger of injury from unauthorized access.</p> <p>There is a danger of injury if unauthorized persons handle the machine.</p> <ul style="list-style-type: none"> ▪ Protect the starting key against unauthorized access during breaks in operation or after completing work.

NOTICE	
	See also instructions in the documentation for the complete machine.

Overview – HATZ instrument boxes

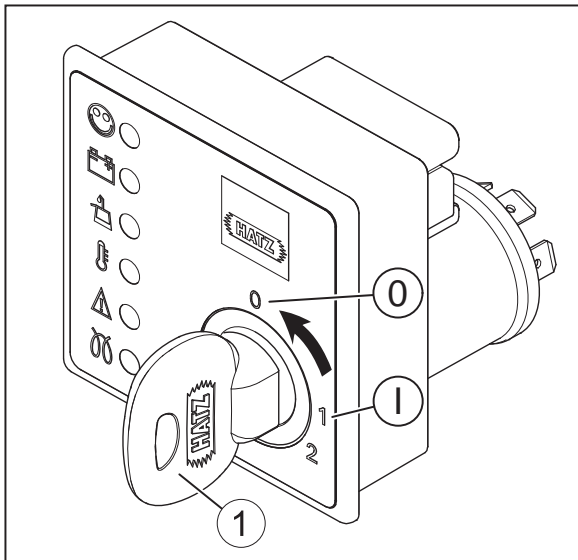

1	Starting key
Ignition lock	
0	Off
I	Operation

Procedure

Step	Activity
1	Turn the starting key to position "0". The engine switches off. All indicator lamps go out. <i>Note:</i> The engine continues running for several seconds after it is switched off. Before performing any further activities, wait until all moving components have come to a complete standstill.
2	Remove the starting key.

NOTICE

 **Danger of exhaustive battery discharge.**

- When the machine is switched off, always turn the starting key to position "0" or else the battery may become fully discharged.

9.5 Checking the oil level

Safety notes



 **CAUTION**

 **Danger of burns.**

There is a danger of burns when working on a hot engine.

- Wear safety gloves.



⚠ CAUTION	
 	<p>Danger of injury</p> <p>Prolonged contact with engine oil can lead to irritation of the skin.</p> <ul style="list-style-type: none"> ▪ Wear safety gloves. ▪ If there is contact with the skin, thoroughly wash the affected areas of the skin with soap and water.
CAUTION	
	<p>Danger of later engine damage.</p> <ul style="list-style-type: none"> ▪ Operating the engine with an oil level below the min. mark or above the max. mark can lead to engine damage. ▪ When checking the oil level, the engine must be horizontal and have been switched off for a few minutes.

Overview

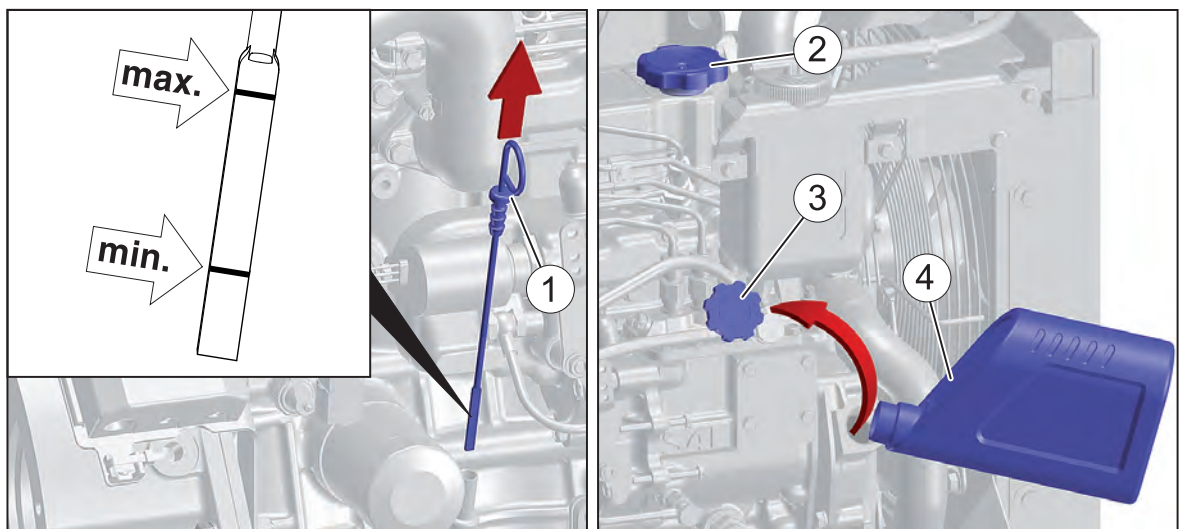

1	Dipstick
2	Oil filler plug, top
3	Oil filler plug, bottom
4	Oil refilling container









Procedure — Checking oil level/adding oil

Step	Activity
1	Switch off the engine and wait several minutes for the engine oil to collect in the crankcase. The engine must be level.
2	Remove contamination on the engine in area of the dipstick (1) and the oil filler plug.
3	Pull out the dipstick and wipe it off with a clean towel.
4	Reinsert the dipstick.
5	Pull out the dipstick and check the oil level.
6	If the oil level is close to the min. mark, add engine oil to the max. mark. For the specification and viscosity, see chapter 4.3 <i>Engine oil</i> , page 17.
7	Reinsert the dipstick.

9.6 Refueling

This diesel engine is intended for installation in a machine or for assembly with other machines to form a machine and does not have its own fuel tank. Follow the instructions from the manufacturer and comply with the following safety information.



Safety notes

 DANGER	
 	<p>Fire hazard from fuel.</p> <p>Leaked or spilled fuel can ignite on hot engine parts and cause serious burn injuries.</p> <ul style="list-style-type: none"> ▪ Only refuel when the engine is switched off and has cooled down. ▪ Never refuel in the vicinity of open flames or sparks that can cause ignition. ▪ Do not smoke. ▪ Do not spill fuel.
 CAUTION	
	<p>Danger of environmental damage from spilled fuel.</p> <p>Do not overfill the fuel tank and do not spill fuel.</p> <ul style="list-style-type: none"> ▪ Collect any leaking fuel and dispose of it according to local environmental regulations.
 CAUTION	
 	<p>Danger of injury.</p> <p>Repeated contact with diesel fuel can cause chapped and cracked skin.</p> <ul style="list-style-type: none"> ▪ Wear safety gloves. ▪ If there is contact with the skin, thoroughly wash the affected areas of the skin with soap and water.
CAUTION	
	<p>Engine damage from using low quality fuel.</p> <p>The use of fuel that does not meet the specifications can lead to engine damage.</p> <ul style="list-style-type: none"> ▪ Only use the fuel specified in chapter 4.5 <i>Fuel</i>, page 19. ▪ The use of fuels that do not meet specifications require approval by Motorenfabrik HATZ (main plant).
NOTICE	
	<p>Never run the tank empty if possible, as otherwise air can enter the fuel system. This can lead to damage to the injection system.</p> <p>If the tank is still run empty, proceed as follows:</p> <ul style="list-style-type: none"> ▪ Fill the fuel tank with diesel fuel. ▪ Bleed the fuel system (see chapter 8.4 <i>Venting the fuel system</i>, page 70).

10 Maintenance

10.1 General maintenance instructions

Safety notes

 WARNING	
	<p>Danger of injury from failure to follow the Operating Instructions and from performing unauthorized tasks on the machine.</p> <ul style="list-style-type: none"> ▪ Follow all instructions. ▪ Do not perform activities for which no qualification is available. Contact properly trained personnel if necessary.

NOTICE	
	<p>Comply with the safety chapter!</p> <p>Follow the basic safety instructions in chapter 3 <i>Safety</i>, page 7.</p>

- Maintenance tasks may only be performed by trained personnel.
- Accident prevention measures must be in accordance with the local accident prevention regulations.
- Perform setting and maintenance work at the specified intervals.
- Replace defective machine parts as soon as possible.
- Always wear personal protection equipment.
- Only use fully functional tools.
- Installation of unsuitable spare parts can lead to problems. We cannot accept liability for direct damage or secondary damage that results from this. We therefore recommend the use of **genuine Hatz spare parts**.
- Closely adhere to the maintenance conditions prescribed in this manual.
- Only make changes to the machine in agreement with the manufacturer.
- Only perform maintenance work when the engine is switched off.
- After completing maintenance work, check that all tools, screws, aids, and other objects are removed from the machine, and that all safety equipment has been replaced.
- Before starting, ensure that no persons are located in the danger zone of the engine or machine.



Performance of maintenance work

The entire machine is designed to be maintenance friendly. Parts that require maintenance are easily accessible.

- Perform maintenance work faithfully at the specified intervals to prevent premature wear of the machine.
- Follow the notice and warning labels on the machine.
- Always retighten screw connections loosened during maintenance work.
- After the necessary maintenance and repair work is completed, perform a function test (test run).
- For maintenance work that is not listed and described in the maintenance documentation, please contact your nearest **HATZ service station**.

10.2 Maintenance work

Safety note

 CAUTION	
	<p>Danger of injury from ignoring the maintenance instructions.</p> <ul style="list-style-type: none"> ▪ Only perform maintenance work when the engine is switched off. ▪ Protect the starting key from unauthorized access. ▪ Disconnect the negative battery terminal. ▪ When the maintenance work has been completed, ensure that all tools are removed from the machine.

10.2.1 Maintenance plan

NOTICE	
	<p>The maintenance intervals listed below apply to standard applications. If the operating conditions differ significantly from the usual use cases, it is possible that Hatz and the manufacturer of the complete machine reached a special agreement stipulating shorter or longer maintenance intervals. Corresponding information regarding different maintenance intervals can be found in the documentation of the complete machine.</p>

Daily checks

Maintenance interval	Activity/check	Section
Every 8–15 operating hours or every day before starting	Checking the oil level	<i>9.5 Checking the oil level, page 76</i>
	Checking the intake area of the combustion air	<i>10.2.2 Checking the intake area of the combustion air, page 81</i>
	Check the cooler fins for dirt accumulation	<i>10.2.3 Checking the cooler fins for dirt accumulation, page 82</i>
	Checking the cooling system	<i>10.2.4 Checking the cooling system, page 83</i>

Initial maintenance of new or rebuilt engines

Maintenance interval	Maintenance step/check	Section
After the first 50 operating hours:	Change the engine oil and oil filter	<i>10.2.5 Change the engine oil and oil filter, page 86</i>
	Checking the screw connections	<i>10.2.9 Checking the screw connections, page 94</i>

Maintenance





Maintenance interval	Maintenance step/check	Section
Every 250 operating hours or every 12 months	Check and clean the cooler fins ¹⁾	<i>10.2.6 Cleaning the radiator fins, page 89</i>
	Change the engine oil and oil filter ¹⁾	<i>10.2.5 Change the engine oil and oil filter, page 86</i>
	Check and adjust the belt and belt tension ¹⁾	<i>10.2.7 Checking the belt and belt tension, page 90</i>
	Drain the water separator ¹⁾	<i>10.2.10 Draining the water separator, page 94</i>

Maintenance interval	Maintenance step/check	Section
Every 500 operating hours or every 12 months	Change the fuel prefilter ¹⁾	10.2.11 Changing the fuel prefilter, page 95
	Replace the main fuel filter ¹⁾	10.2.12 Changing the main fuel filter, page 97
	Air filter maintenance ¹⁾	10.2.13 Air filter maintenance, page 99
	Check the anti-freeze concentration of the coolant ¹⁾	10.2.4 Checking the cooling system, page 83
	Check and adjust the tappet clearance ¹⁾ (to be carried out by a trained specialist)	
	Check the glow plugs (to be carried out by a trained specialist)	
	Check the screw connections ¹⁾	10.2.9 Checking the screw connections, page 94
Every 2 years	Changing the coolant	10.2.14 Changing the coolant, page 102
Every 1500 operating hours	Clean the injection nozzles (to be carried out by a trained specialist)	
Every 3000 operating hours	Check and maintain the injection nozzles (to be carried out by a trained specialist)	

¹⁾ Maintenance according to the maintenance interval or after 12 months, whichever comes first.

10.2.2 Checking the intake area of the combustion air

Safety notes

 CAUTION	
 	<p>Danger of burns.</p> <p>There is a danger of burns when working on a hot engine.</p> <ul style="list-style-type: none"> ▪ Let the engine cool. ▪ Wear safety gloves.
CAUTION	
	<p>Damage to the cyclone precleaner from improper cleaning.</p> <ul style="list-style-type: none"> ▪ Never clean the cyclone precleaner with hard or sharp-edged tools such as spatulas or screwdrivers to avoid damage. A damaged cyclone precleaner has poor efficiency.
NOTICE	
	<p>In case of heavy contamination, shorten the maintenance intervals accordingly (see chapter 10.2.1 Maintenance plan, page 80).</p>

Overview (HATZ air filter)

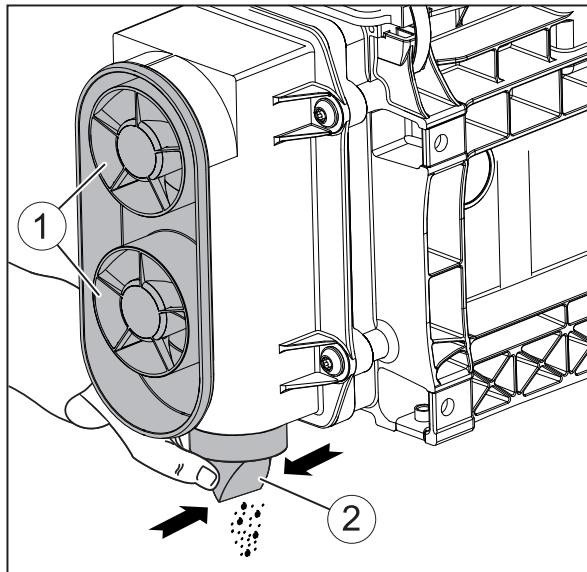

1	Intake opening for combustion air (cyclone precleaner)
2	Dust discharge valve

Procedure

Step	Activity
1	Check the intake opening (1) for coarse contamination such as leaves, heavy dust deposits etc., and clean if necessary. For details on cleaning, see <i>10.2.13 Air filter maintenance, page 99</i> .
2	Check that the dust discharge valve (2) is clear. Remove dust seals by pressing them together.

10.2.3 Checking the cooler fins for dirt accumulation

Safety notes

⚠ CAUTION	
 	<p>Danger of burns.</p> <p>There is a danger of burns when working on a hot engine.</p> <ul style="list-style-type: none"> ▪ Let the engine cool. ▪ Wear safety gloves.
⚠ CAUTION	
 	<p>Danger of injury.</p> <p>When working with compressed air, foreign bodies may fly into your eyes.</p> <ul style="list-style-type: none"> ▪ Wear safety goggles. ▪ Never direct the compressed air jet toward people or toward yourself.
CAUTION	
	<p>Danger of engine damage from overheating.</p> <p>The engine temperature indicator lights up as soon as the engine becomes inadmissibly hot.</p> <ul style="list-style-type: none"> ▪ Switch off the engine and eliminate the cause.

NOTICE	
	In case of heavy contamination, shorten the maintenance intervals accordingly (see chapter 10.2.1 <i>Maintenance plan</i> , page 80).

Overview

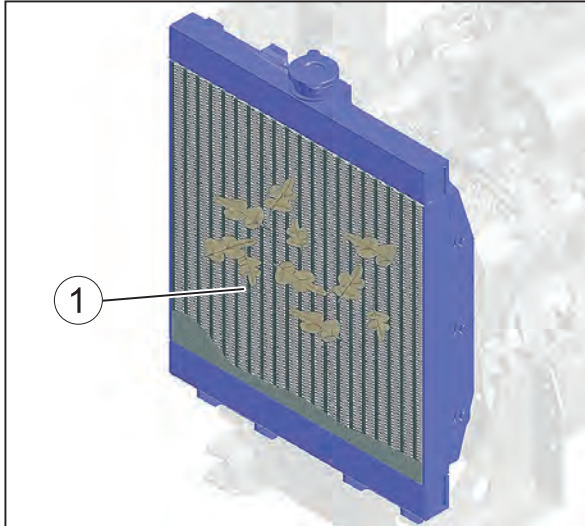











1	Cooler fins
---	-------------



Procedure

Step	Activity
1	Check the cooler fins (1) for coarse contamination such as leaves, heavy dust deposits etc., and clean if necessary (see chapter 10.2.6 <i>Cleaning the radiator fins</i> , page 89).

10.2.4 Checking the cooling system

Safety notes

 CAUTION				
<table style="width: 100%; border-collapse: collapse;"> <tr> <td style="width: 15%; text-align: center; vertical-align: middle;">  </td> <td style="padding: 5px;"> <p>Danger of scalding and risk of environmental damage due to hot coolant.</p> <ul style="list-style-type: none"> ▪ Excess coolant is drained via the sealing cap of the cooler and channeled to the overflow container. After topping up the cooling system never move parts of your body or face close to the sealing cap. </td> </tr> <tr> <td style="text-align: center; vertical-align: middle;">  </td> <td style="padding: 5px;"> <ul style="list-style-type: none"> ▪ Never top up coolant above the MAX mark on the overflow container. ▪ Never stop escaping coolant with your bare hands. </td> </tr> </table>		<p>Danger of scalding and risk of environmental damage due to hot coolant.</p> <ul style="list-style-type: none"> ▪ Excess coolant is drained via the sealing cap of the cooler and channeled to the overflow container. After topping up the cooling system never move parts of your body or face close to the sealing cap. 		<ul style="list-style-type: none"> ▪ Never top up coolant above the MAX mark on the overflow container. ▪ Never stop escaping coolant with your bare hands.
	<p>Danger of scalding and risk of environmental damage due to hot coolant.</p> <ul style="list-style-type: none"> ▪ Excess coolant is drained via the sealing cap of the cooler and channeled to the overflow container. After topping up the cooling system never move parts of your body or face close to the sealing cap. 			
	<ul style="list-style-type: none"> ▪ Never top up coolant above the MAX mark on the overflow container. ▪ Never stop escaping coolant with your bare hands. 			
 CAUTION				
<table style="width: 100%; border-collapse: collapse;"> <tr> <td style="width: 15%; text-align: center; vertical-align: middle;">  </td> <td style="padding: 5px;"> <p>Danger of burns.</p> <p>There is a danger of burns when working on a hot engine.</p> <ul style="list-style-type: none"> ▪ Let the engine cool before maintenance. </td> </tr> </table>		<p>Danger of burns.</p> <p>There is a danger of burns when working on a hot engine.</p> <ul style="list-style-type: none"> ▪ Let the engine cool before maintenance. 		
	<p>Danger of burns.</p> <p>There is a danger of burns when working on a hot engine.</p> <ul style="list-style-type: none"> ▪ Let the engine cool before maintenance. 			

⚠ CAUTION	
 	<p>Danger of burns.</p> <p>There is a danger of burns when working on a hot cooling system. The cooling system is pressurized when the engine is hot.</p> <ul style="list-style-type: none"> ▪ Let the engine cool. ▪ Wear safety gloves.
CAUTION	
	<p>Danger of later engine damage.</p> <ul style="list-style-type: none"> ▪ Operating the engine with a coolant level below the MIN. mark can lead to engine damage. ▪ When checking the coolant level, the engine must be horizontal and switched off.

Overview

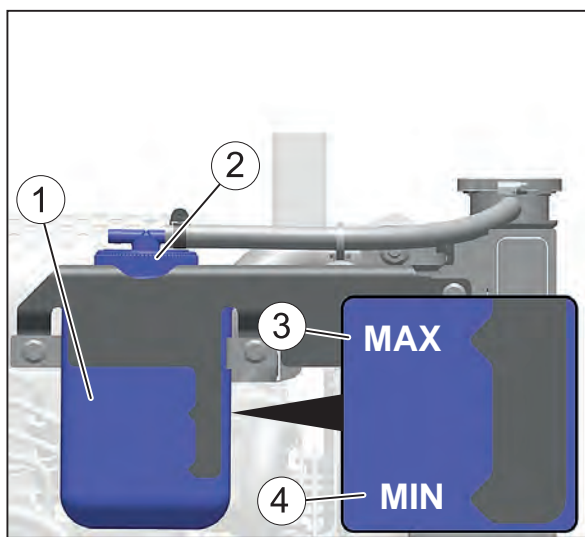

1	Overflow container
2	Screw plug on the overflow container
3	MAX - Maximum coolant level in overflow container
4	MIN - Minimum coolant level in overflow container

Procedure for checking the coolant level

Step	Activity
1	The coolant must be between the MIN and MAX marks on a switched-off and cooled-down engine. For a warm engine, the level can also be slightly above the MAX mark.

Procedure for topping up coolant

Step	Activity
1	Carefully open the screw plug (2).
2	Top up the prepared coolant to the MAX mark on the overflow container. For the preparation of the coolant, see section 4.4 <i>Coolant</i> , page 17.
3	Tighten the sealing cap (2) by hand.

NOTICE	
	<p>Since the corrosion and antifreeze concentration decreases over time, carry out a check with a commercially available antifreeze tester as per the maintenance schedule. If the concentration is too low, either:</p> <ul style="list-style-type: none"> ▪ drain part of the coolant and bring to the required frost safety level by adding radiator protective fluid, or ▪ replace the entire filling of coolant (see section 10.2.14 <i>Changing the coolant</i>, page 102).

Checking the cooling system for leaks

Coolants losses are mostly caused by leaks in the cooling system.

On a non-leaking cooling system, losses only occur when the coolant boils and this then causes coolant to be pressed out of the cooling system at the sealing cap on the overflow container. The cause of this can be contamination in the area of the cooler fins (see chapter 10.2.3 *Checking the cooler fins for dirt accumulation*, page 82).

Overview

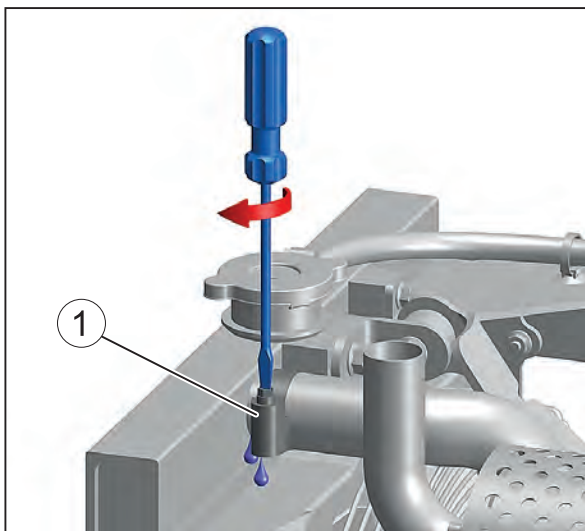

1	Hose clip
---	-----------

Procedure









Step	Activity
1	Check the cooling system for leaks and rectify the cause immediately - in case of doubt consult HATZ Service for advice.
2	When hose connections are loose, retighten the hose clips (1).

10.2.5 Change the engine oil and oil filter

This chapter contains the following subchapters:

- **Changing the oil filter**
- **Draining the engine oil**
- **Filling the engine oil**
- **Concluding the inspection work**

Safety notes

 CAUTION	
 	<p>Danger of burns.</p> <p>When working on the engine, there is a danger of burns from hot oil.</p> <ul style="list-style-type: none"> ▪ Wear personal protective equipment (gloves).
 CAUTION	
	<p>Danger of environmental damage from spilled used oil.</p> <p>Used oil is water-polluting.</p> <ul style="list-style-type: none"> ▪ Do not allow them to enter the ground water, water bodies, or sewage system. ▪ Collect the used oil and dispose of it according to local environmental regulations.
 CAUTION	
 	<p>Danger of injury</p> <p>Prolonged contact with engine oil can lead to irritation of the skin.</p> <ul style="list-style-type: none"> ▪ Wear safety gloves. ▪ If there is contact with the skin, thoroughly wash the affected areas of the skin with soap and water.
CAUTION	
	<p>Danger of later engine damage.</p> <ul style="list-style-type: none"> ▪ Operating the engine with an oil level below the min. mark or above the max. mark can lead to engine damage. ▪ When checking the oil level, the engine must be horizontal and have been switched off for a few minutes.
NOTICE	
	<ul style="list-style-type: none"> ▪ The engine must be level. ▪ The engine must be switched off. ▪ Only drain engine oil while it is warm.

Changing the oil filter

Overview

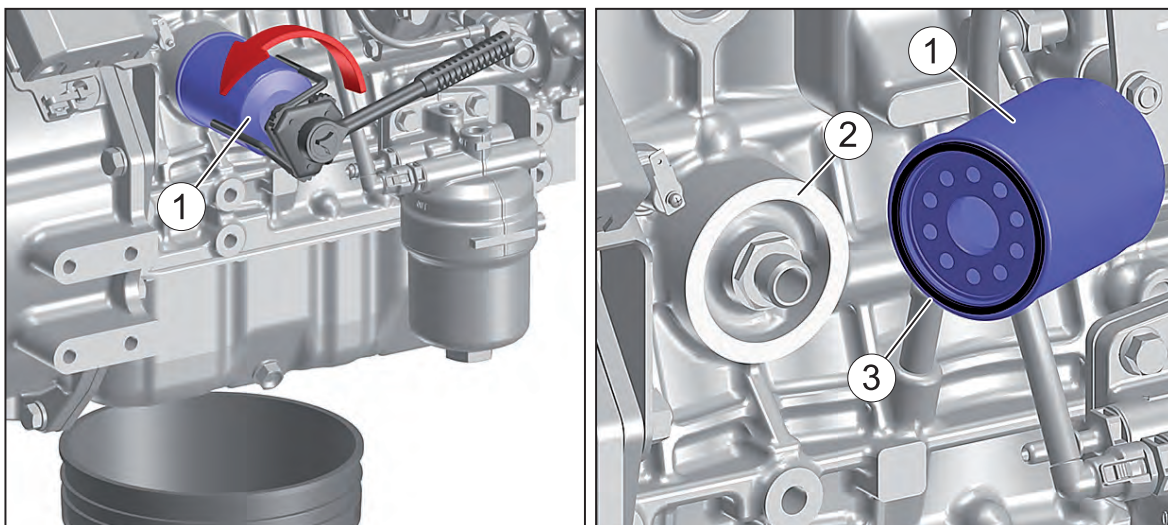

1	Oil filter
2	Sealing surface
3	Sealing ring

Procedure

Step	Activity
1	Keep a container ready for collecting the used oil.
2	Loosen the oil filter (1) with a strap wrench or similar and unscrew it.
3	Dispose of the old filter in accordance with local environmental regulations.
4	Thoroughly clean the sealing surface (2).
5	Lightly oil the sealing lip (3) of the new oil filter.
6	Screw in the oil filter and tighten it by hand .

Draining the engine oil

Overview

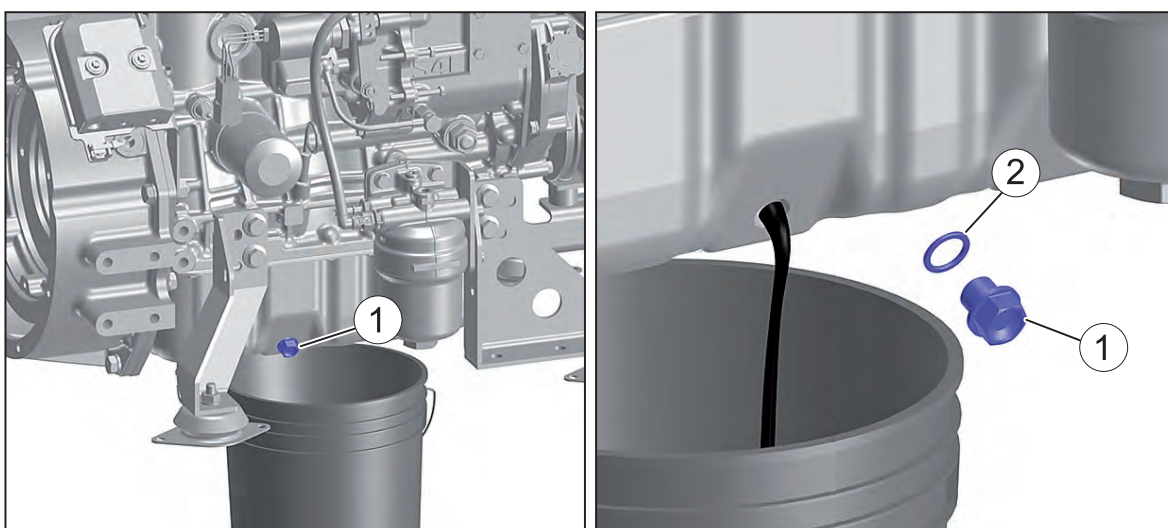

1	Oil drain screw
2	Sealing ring

Procedure

Step	Activity
1	Keep a container ready for collecting the used oil. The container must be large enough to hold the entire amount of engine oil. For the engine oil capacity, see chapter 4.1 <i>Engine information and filling quantities</i> , page 16.
2	Unscrew the oil drain screw (1) and drain the used oil entirely.
3	Screw in the cleaned oil drain screw with the new sealing ring and tighten. Tightening torque: 40 Nm.

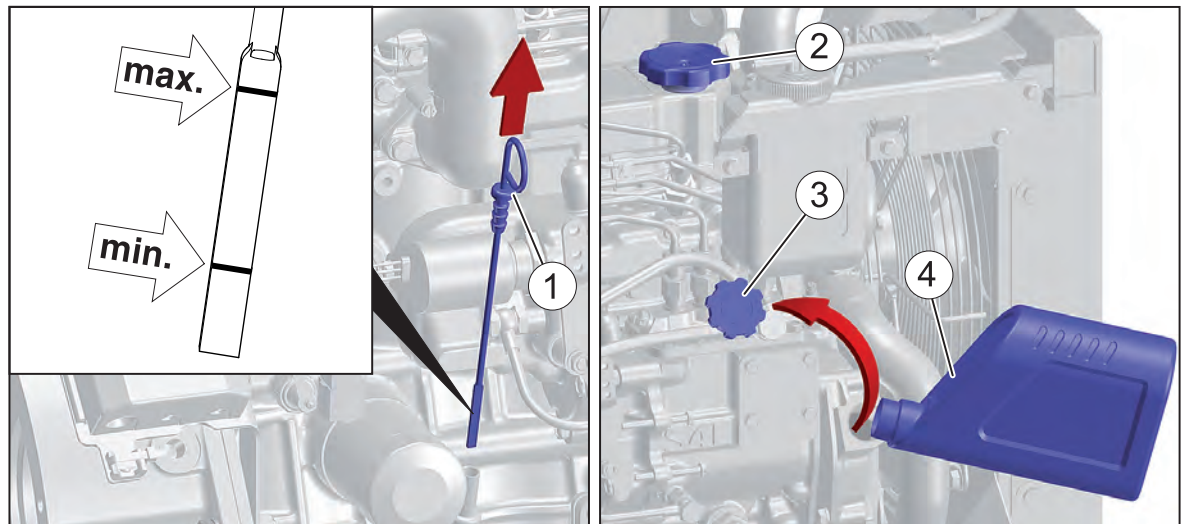
Filling the engine oil**Overview**

1	Dipstick
2	Oil filler plug, top
3	Oil filler plug, bottom
4	Oil refilling container

Procedure











Step	Activity
1	Pull out the dipstick (1) and wipe it off with a clean towel.
2	Unscrew the oil filler plug (2) or (3).
3	Fill with engine oil. For the specification and viscosity, see section 4.3 <i>Engine oil</i> , page 17. For the filling quantity, see section 4.1 <i>Engine information and filling quantities</i> , page 16.
4	Reinsert the dipstick.
5	Pull out the dipstick and check the oil level.
6	If necessary, add engine oil to the max. mark.
7	Reinsert the dipstick.
8	Screw in the oil filler plug.

Concluding the inspection work

Step	Activity
1	Check the oil level after a short test run and correct if necessary.
2	Check the oil filter for tightness and retighten by hand if necessary.

10.2.6 Cleaning the radiator fins

Safety notes

 DANGER	
	<p>Danger of explosion from flammable cleaning agents.</p> <p>Cleaning with benzene is an explosion hazard. It is highly flammable, can become electrostatically charged, and can generate an explosive gas/air mixture.</p> <ul style="list-style-type: none"> ▪ Use halogen-free, cold cleaners with a high flash point for cleaning. ▪ Comply with manufacturer's instructions.
 CAUTION	
	<p>Danger of environmental pollution due to oil and cleaning agents.</p> <p>Oil and cleaning agents are hazardous to the environment.</p> <ul style="list-style-type: none"> ▪ Do not allow them to enter the ground water, water bodies, or sewage system. ▪ Only clean the machine at the washing area intended for this.
 CAUTION	
 	<p>Danger of burns.</p> <p>There is a danger of burns when working on a hot engine.</p> <ul style="list-style-type: none"> ▪ Let the engine cool. ▪ Wear safety gloves.
 CAUTION	
 	<p>Danger of injury.</p> <p>When working with compressed air, foreign bodies may fly into your eyes.</p> <ul style="list-style-type: none"> ▪ Wear safety goggles. ▪ Never direct the compressed air jet toward people or toward yourself.
CAUTION	
	<p>Danger of damage to the machine from incorrect engine cleaning.</p> <ul style="list-style-type: none"> ▪ Let the engine fully cool down before cleaning. ▪ Do not use gasoline or acid-based cleaning agents. ▪ Do not spray electrical and electronic components with a water jet or high pressure jet during cleaning. ▪ Never aim the water jet into the intake opening for combustion air or into the exhaust pipe.
CAUTION	
	<p>Damage to the cooler fins due to improper cleaning.</p> <ul style="list-style-type: none"> ▪ Never clean the cooler fins with a tool such as a spatula or screwdriver. A reduction in cooler performance through bent cooler fins or cooler leaks may be the result.
NOTICE	
	<p>In case of heavy contamination, shorten the maintenance intervals accordingly (see chapter 10.2.1 Maintenance plan, page 80).</p>

Overview

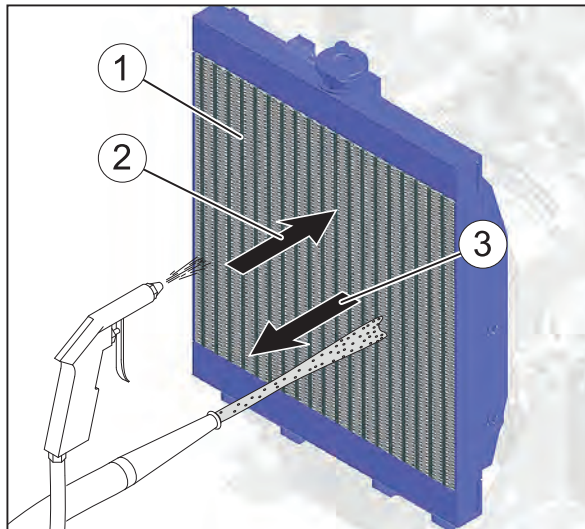

1	Cooler fins
2	Direction of flow of the cooling air with suction fan
3	Direction of flow of the cooling air with pressure fan

Procedure

Step	Activity
Cleaning in case of dry dirt contamination	
1	Clean the radiator fins either with compressed air or flush with a water jet - depending on the amount of accumulated dirt. Work first against the direction of flow of the cooling air and then in the direction of flow.
Cleaning wet or oily dirt contamination	
1	Spray the entire area with a suitable cold cleaner according to the manufacturer's instructions and then clean off with a water jet. Work first against the direction of flow of the cooling air and then in the direction of flow.
2	Identify the cause of the oiling and seal the leak.
After the cleaning	
1	Let the engine run warm until it has completely dried to prevent rust formation.

10.2.7 Checking the belt and belt tension

This section contains the following subsections:

- **Preparation**
- **Checking the belt for damage**
- **Checking and setting the belt tension**

Safety notes

⚠ CAUTION	
	<p>Danger of burns.</p> <p>There is a danger of burns when working on a hot engine.</p> <ul style="list-style-type: none"> ▪ Let the engine cool before maintenance.

Preparation

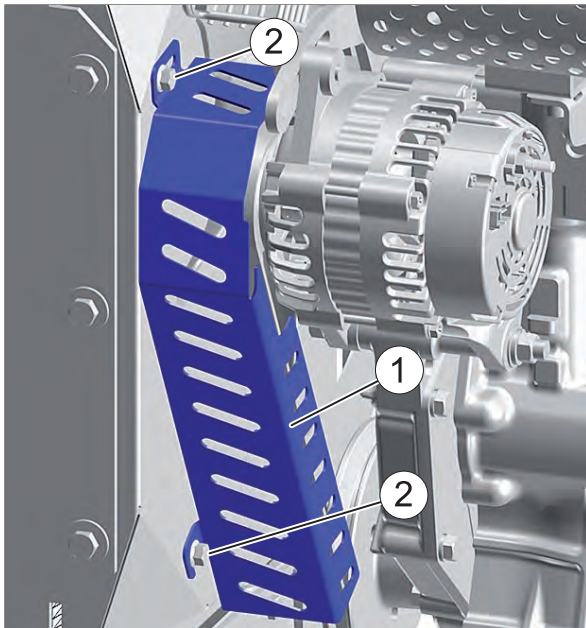

Step	Activity
1	Unscrew the optional belt guard (1). Unscrew the fixing screws (2) for this.

Checking the belt for damage

Procedure

Step	Activity
1	<p>Check the belt for the following damage:</p> <ul style="list-style-type: none"> ▪ Transverse cracks on the inside of the belt. ▪ Detachments on the surface. ▪ Hardened, polish flanks. ▪ Oily dirt contamination. <p>If one or more of these types of damage are present, replace the belt immediately (see section 10.2.8 <i>Changing the belt</i>, page 93).</p>

Checking and setting the belt tension

NOTICE	
	<ul style="list-style-type: none"> ▪ The cause of running noises of the belt is mostly likely that the pretension on the belt is too low. ▪ If the pretension is too low, this causes premature wear. ▪ If the pretension is too high, this can lead to premature wear of the generator bearing and also of the belt. ▪ Regularly check the belt tension; retension the belt if required.

Overview

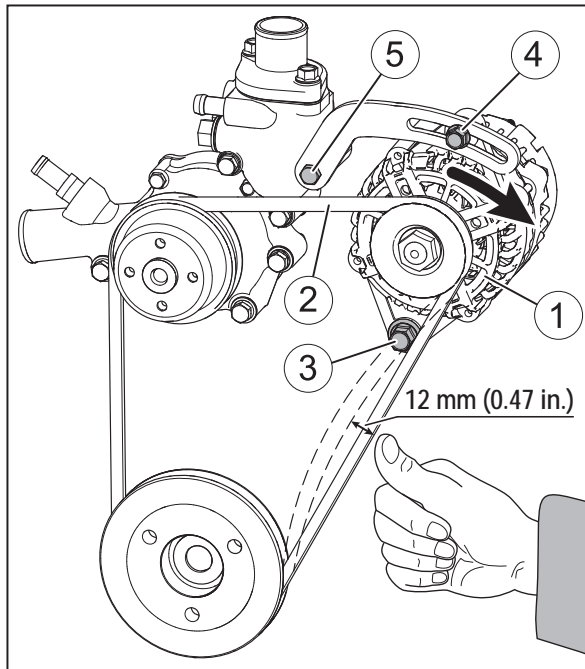

1	Alternator
2	Belts
3	Lower fixing screw on the alternator
4	Upper fixing screw on the alternator
5	Fixing screw of the adjustment plate

Procedure

Step	Activity
Checking the belt tension	
1	As shown in the figure, press against the belt with your thumb and measure the distance that the belt can be pushed in. The belt tension is correct if the distance is 12 mm.
Setting the belt tension	
1	Undo the fixing screws (3, 4 and 5).
2	Turn the generator (1) in the direction of the arrow, hold it and – at the same time – tighten the fixing screws in this position.
3	Check the belt tension again.
4	If necessary, correct the belt tension.

Final steps

Step	Activity
1	Mount the belt guard again.

10.2.8 Changing the belt

Safety note

⚠ CAUTION	
	<p>Danger of burns.</p> <p>There is a danger of burns when working on a hot engine.</p> <ul style="list-style-type: none"> Let the engine cool before maintenance.

Overview

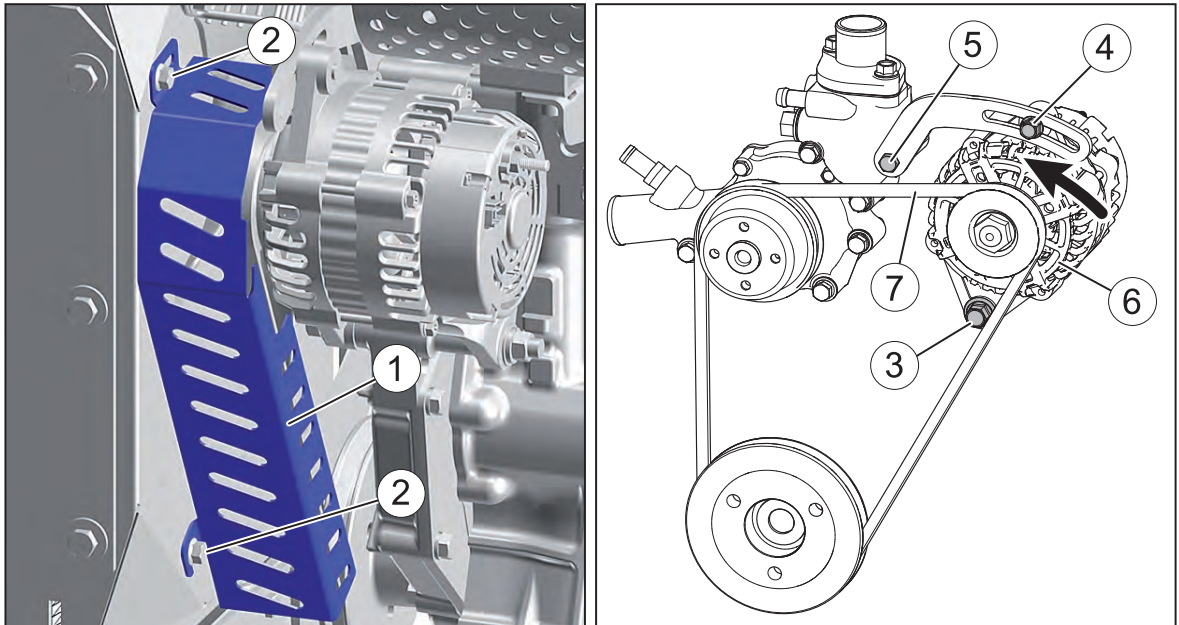

1	Belt guard
2	Fixing screws for belt protector
3	Lower fixing screw on the alternator
4	Upper fixing screw on the alternator
5	Fixing screw of the adjustment plate
6	Alternator
7	Belts

Procedure

Step	Activity
1	Unscrew the optional belt guard (1). Unscrew the fixing screws (2) for this.
2	Undo the fixing screws (2, 4 and 5).
3	Turn the generator (6) in the direction of the arrow to the stop.
4	Remove the loose belt (7) from the pulleys.
5	Check the pulley for perfect condition.
6	Lay the new belt over the pulleys and tighten (see section 10.2.7 <i>Checking the belt and belt tension</i> , page 90).
7	Install the belt guard.

10.2.9 Checking the screw connections

Safety note



NOTICE	
	<ul style="list-style-type: none"> ▪ Only retighten loose screw connections. Screw connections can be secured with thread locking adhesive or tightened to a defined torque. Retightening tight screw connections can cause damage. ▪ The adjusting screws on the injection system are secured with locking varnish and are not permitted to be tightened or adjusted. ▪ Do not retighten the screws for attaching the cylinder head.

Procedure

Step	Activity
1	Check the condition of all screw connections and ensure that they are tight (for exceptions, see note).
2	Tighten any lose screw connections.

10.2.10 Draining the water separator

Safety note

 CAUTION	
	<p>Danger of environmental damage from spilled fuel.</p> <p>When water is drained from the water separator, a small amount of fuel is drained as well.</p> <ul style="list-style-type: none"> ▪ Collect any escaped water/fuel mixture and dispose of it according to local environmental regulations.

Overview

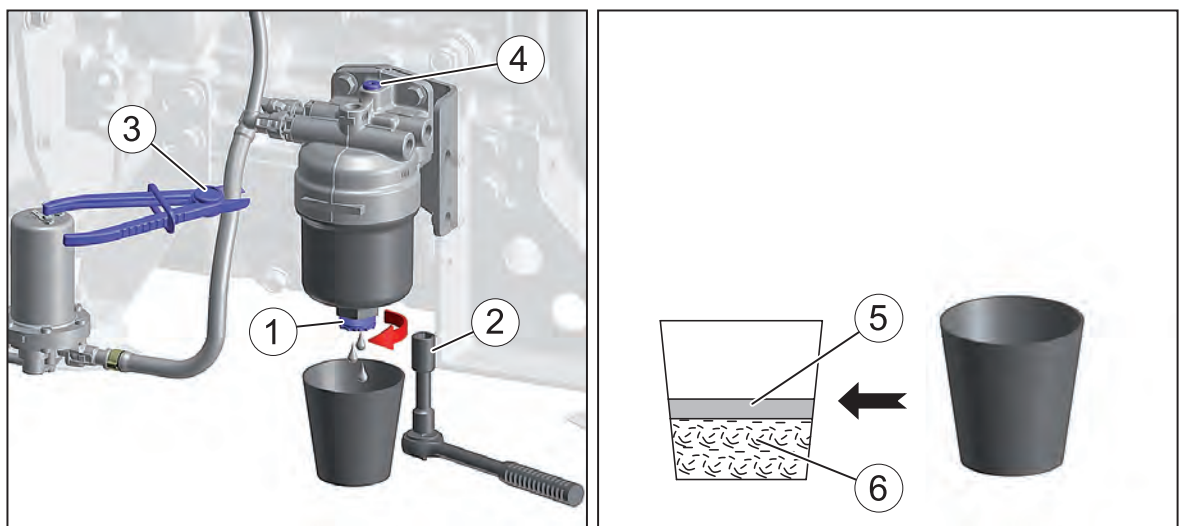











1	Drain screw
2	Socket wrench (13 mm)
3	Hose clip (for a fuel tank positioned low)
4	Vent screw
5	Fuel
6	Water

Procedure

Step	Activity
1	Place a suitable container under the drain screw (1).
2	Open the drain screw (1) using the socket wrench (2) and drain the water into the container.
3	If not enough liquid escapes, undo the additional vent screw (4). <i>NOTE:</i> If the fuel tank is lower than the main fuel filter, the fuel supply line must be disconnected with a hose clip (3). Otherwise fuel will run back into the fuel tank after the drain screw has been unscrewed.
4	As soon as fuel escapes, close the drain screw (1) and vent screw (4). <i>NOTE:</i> First water (6) escapes, then fuel (5). This can be seen by a clear separating line.
5	Disconnected fuel supply line is released again. Dispose of the water/fuel mixture in accordance with the local environmental regulations.

10.2.11 Changing the fuel prefilter

Safety notes

 DANGER	
 	<p>Fire hazard from fuel</p> <p>Leaked or spilled fuel can ignite on hot engine parts and cause serious burn injuries.</p> <ul style="list-style-type: none"> ▪ Do not spill fuel. ▪ No open flames when working on the fuel system. ▪ Do not smoke.
 CAUTION	
	<p>Danger of burns.</p> <p>There is a danger of burns when working on a hot engine.</p> <ul style="list-style-type: none"> ▪ Let the engine cool before maintenance.
 CAUTION	
 	<p>Danger of injury.</p> <p>Repeated contact with diesel fuel can cause chapped and cracked skin.</p> <ul style="list-style-type: none"> ▪ Wear safety gloves. ▪ If there is contact with the skin, thoroughly wash the affected areas of the skin with soap and water.
 CAUTION	
	<p>Danger of environmental damage from spilled fuel.</p> <p>When the filter is removed, a small amount of fuel is drained as well.</p> <ul style="list-style-type: none"> ▪ Collect any escaping fuel and dispose of it according to local environmental regulations.
CAUTION	
	<p>Dirt particles can damage the injection system.</p> <ul style="list-style-type: none"> ▪ Maintain clean conditions to ensure dirt does not enter the fuel line.

Overview

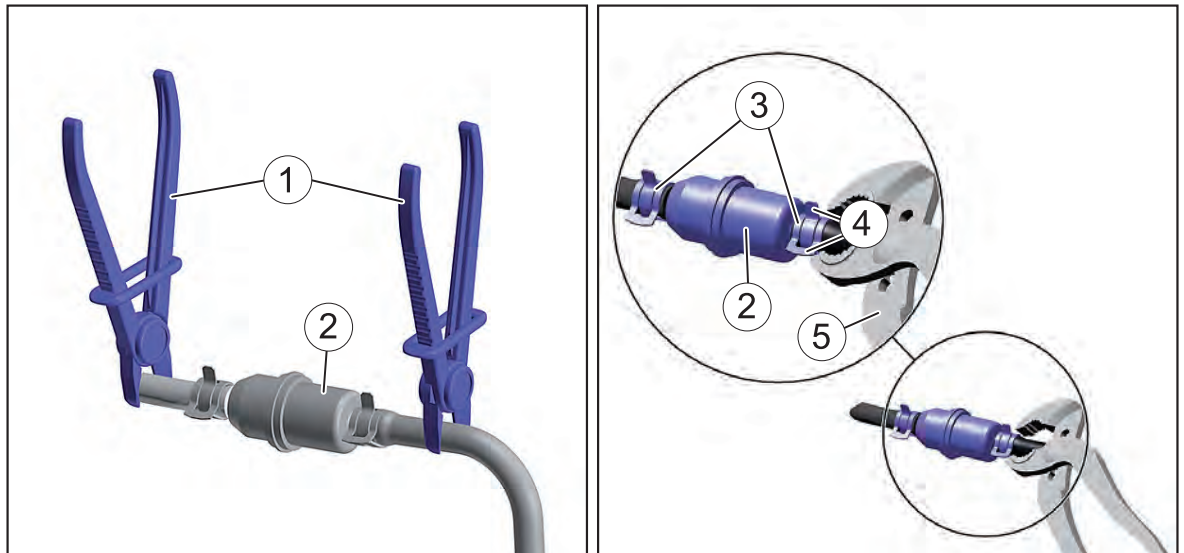







1	Hose clip
2	Fuel prefilter
3	Hose clamp
4	Tabs on the hose clamp
5	Pliers

Procedure

Step	Activity
1	Block the fuel supply line upstream and downstream of the fuel prefilter (2) using hose clips (1).
2	Place a suitable container under the fuel prefilter to collect emerging fuel.
3	Release the hose clamps (3) and slide them to the back. To do so, squeeze the tabs (4) together with suitable pliers (5).
4	Unscrew the fuel prefilter (2) and dispose of it according to local environmental regulations.
5	Insert a new fuel prefilter. Observe the flow-through direction (arrows).
6	Slide the hose clamps to their original position.
7	Start the engine and perform a test run.
8	Check the filter and lines for tightness after a brief trial run.

10.2.12 Changing the main fuel filter

Safety notes

⚠ DANGER	
 	<p>Fire hazard from fuel</p> <p>Leaked or spilled fuel can ignite on hot engine parts and cause serious burn injuries.</p> <ul style="list-style-type: none"> Do not spill fuel. No open flames when working on the fuel system. Do not smoke.
⚠ CAUTION	
	<p>Danger of burns.</p> <p>There is a danger of burns when working on a hot engine.</p> <ul style="list-style-type: none"> Let the engine cool before maintenance.
⚠ CAUTION	
 	<p>Danger of injury.</p> <p>Repeated contact with diesel fuel can cause chapped and cracked skin.</p> <ul style="list-style-type: none"> Wear safety gloves. If there is contact with the skin, thoroughly wash the affected areas of the skin with soap and water.
⚠ CAUTION	
	<p>Danger of environmental damage from spilled fuel.</p> <p>When the filter is removed, a small amount of fuel is drained as well.</p> <ul style="list-style-type: none"> Collect any escaping fuel and dispose of it according to local environmental regulations.
CAUTION	
	<p>Dirt particles can damage the injection system.</p> <ul style="list-style-type: none"> Maintain clean conditions to ensure dirt does not enter the fuel line. Only install fuel filters dry and do not prefill in order to avoid contamination.

Overview

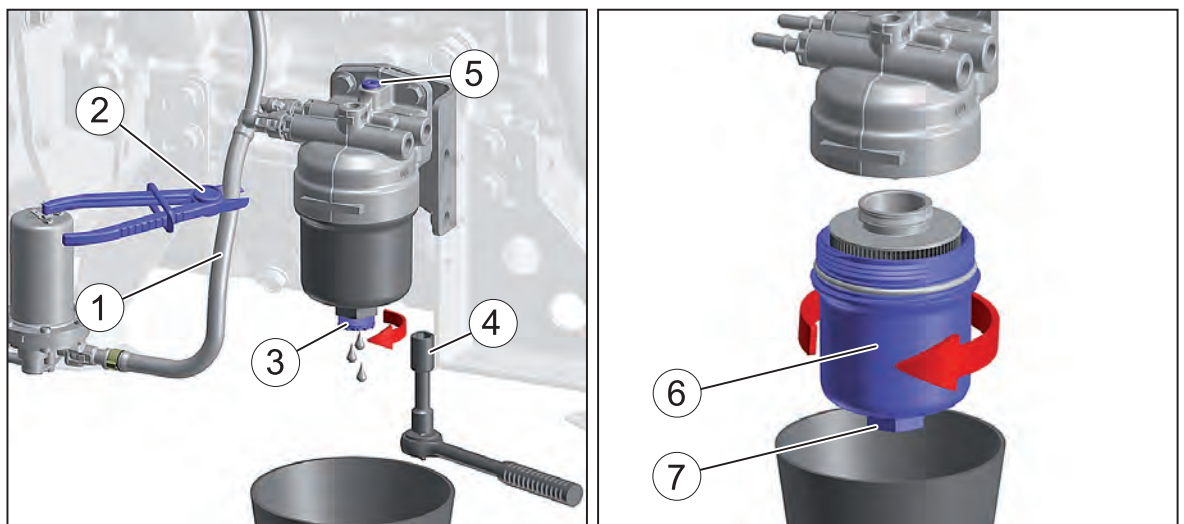

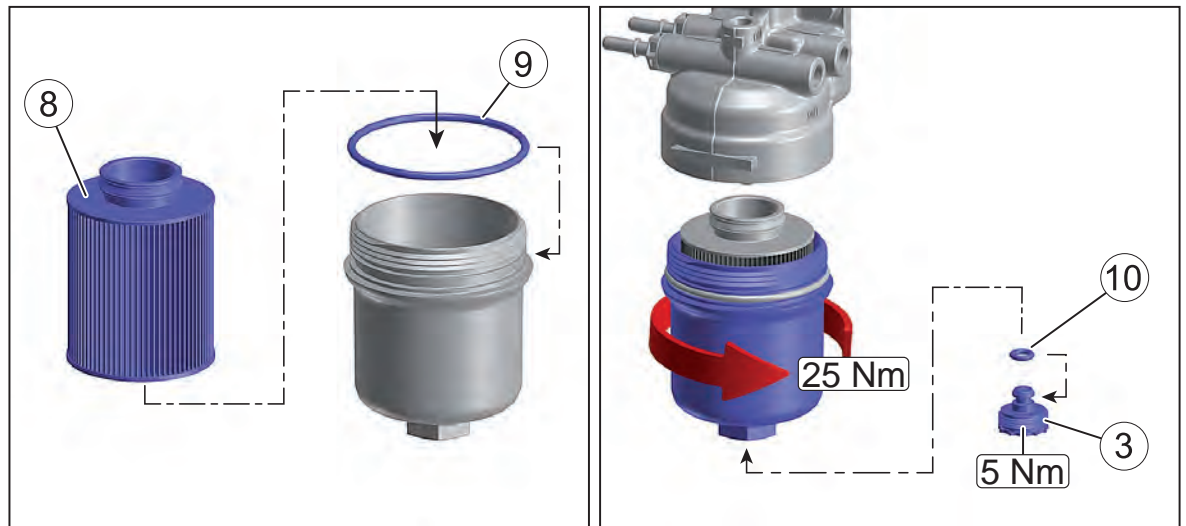

1	Fuel feed line
2	Hose clip
3	Drain screw
4	Socket wrench (13 mm)
5	Vent screw
6	Plastic screw cap
7	Hexagon for fitting a socket or ring wrench
8	filter insert
9	Sealing ring for plastic screw cap
10	Sealing ring for drain screw

Procedure

Step	Activity
1	Block the fuel feed line (1) using the hose clip (2).
3	Place a suitable container under the filter (min. volume of 1.0 liter) to collect escaping fuel.
4	First release the drain screw (3) using the socket wrench (4), then the vent screw (5), and drain the fuel.
5	Then unscrew the drain screw (3) completely and put it aside.
6	Fit the socket wrench or ring wrench onto the hexagon (7) and unscrew the plastic screw cap (6).
7	Dispose of the filter insert (8) and sealing ring (9) in accordance with local environmental regulations.
8	Lightly oil the new sealing ring and install it.
9	Insert the new filter insert into the screw cap.
10	Screw in the screw cap and tighten it to the specified tightening torque.
11	Dispose of the sealing ring (10) in accordance with local environmental regulations.
12	Lightly oil the new sealing ring and install it.
13	Screw in the drain screw (3) and tighten it to the specified tightening torque.
	Tighten the vent screw (5). Tightening torque: 15 Nm.
15	Release the fuel feed line.
16	Bleed the fuel system (see chapter 8.4 <i>Venting the fuel system</i> , page 70).
17	Start the engine and perform a test run.

Step	Activity
18	After the test run, check the main fuel filter for leaks.

10.2.13 Air filter maintenance

This section contains the following subsections:

- Clean the cyclone precleaner
- Change the air filter cartridge

Cleaning the cyclone precleaner

If heavily contaminated, dismantle the cyclone precleaner and clean the individual parts.

Overview

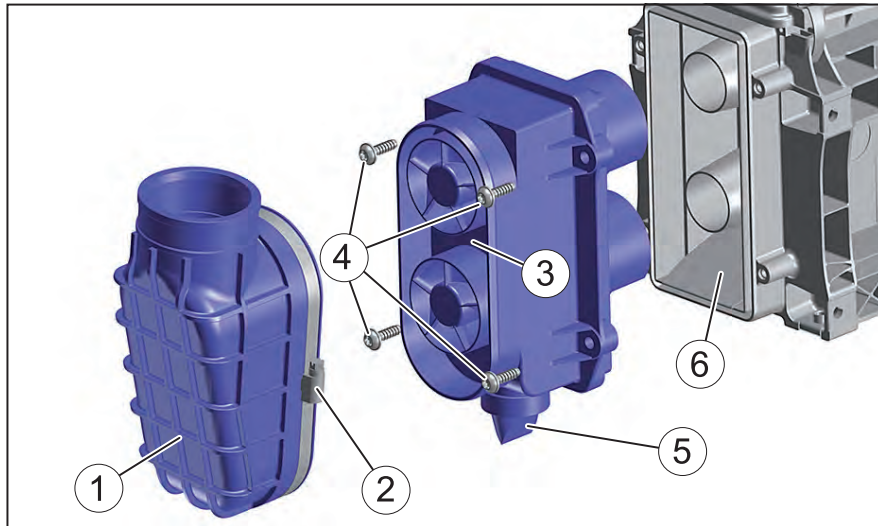

1	Add-on connecting piece (option)
2	Fastening clamp
3	Cyclone precleaner
4	Fastening screws (4 pieces)
5	Dust discharge valve
6	Housing

Procedure

Step	Activity
1	Undo the fastening clamp (2).
2	Pull the add-on connecting piece (1) with the fastening clamp (2) off of the cyclone precleaner (3).
3	Unscrew the fixing screws (4).
4	Remove the cyclone precleaner (3).
5	Pull the dust discharge valve (5) off of the cyclone precleaner.
6	Rinse the individual parts in water or soapy water and let dry.
7	Wipe out the filter housing (6).
8	Mount the cyclone precleaner, dust discharge valve and add-on connecting piece again.

Changing the air filter cartridge

NOTICE



- Replace a soiled filter cartridge immediately, even if the maintenance interval has not been reached.
- The filter cartridge may not be washed out or beaten out.
- We also advise against blowing out the filter cartridge. This can cause tears in the filter paper and deformation of the filter. Dirt particles can be pressed even deeper into the filter paper. This can destroy the fine structure of the filter and reduce the filter effectiveness. This, in turn, leads to premature wear of the engine.
- Even minor damage in the areas of the sealing surface, filter paper, or filter cartridge makes reuse impossible.
- Never let the engine run without a filter cartridge!

Overview

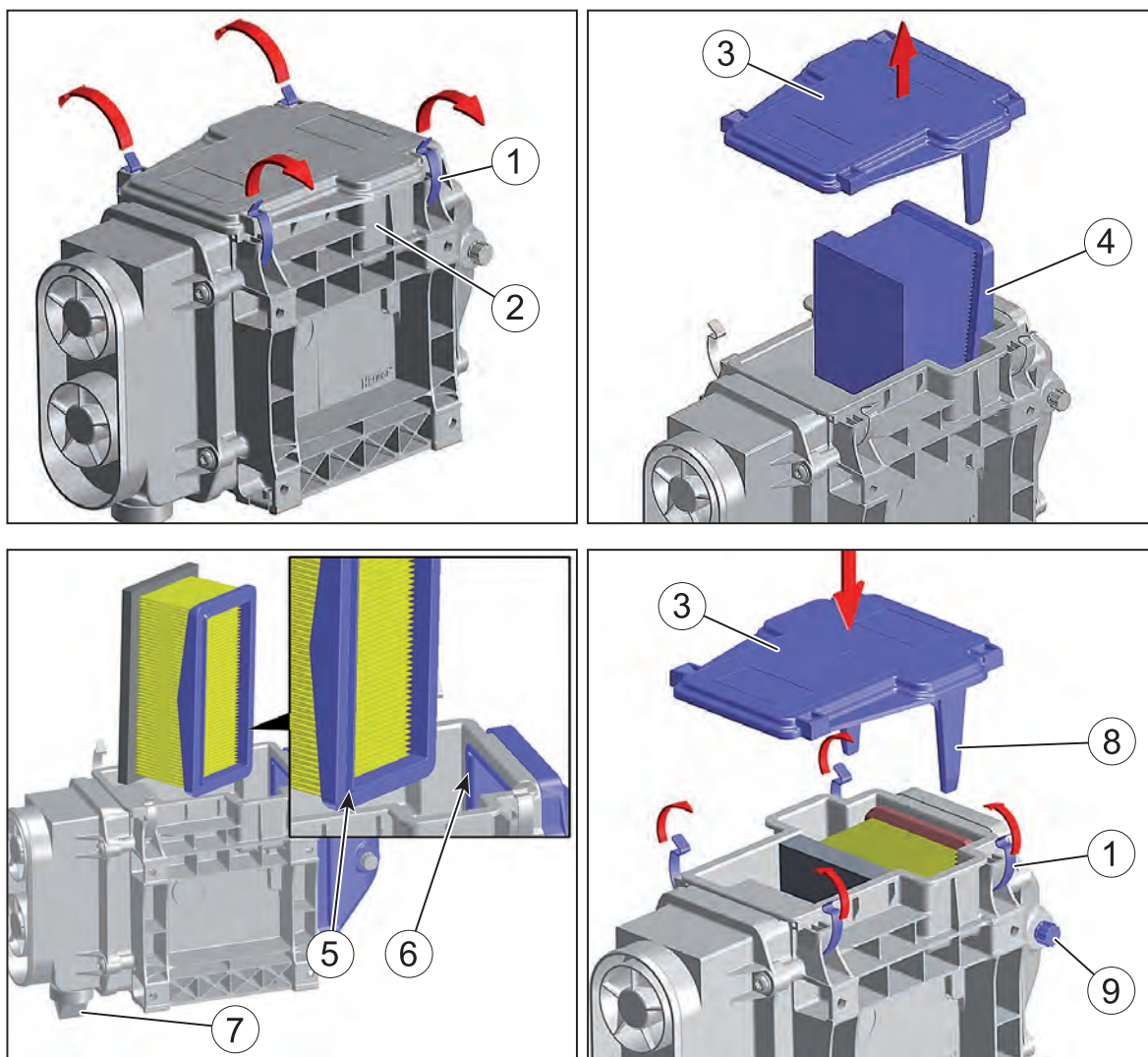

1	Holding clamps (4 pieces)
2	Air filter housing
3	Air filter cover
4	Filter cartridge
5	Sealing surface on the filter cartridge
6	Sealing surface in the air filter box
7	Dust discharge valve

8	Holding tab for filter cartridge
9	Screw plug Attention! The screw plug must be tightened by hand. It must be present, or else the engine can draw in unfiltered air.

Procedure





Step	Activity
1	Open the holding clamps (1).
2	Remove the air filter cover (3).
2	Pull out the filter cartridge (4) and dispose of it in accordance with local environmental regulations.
3	Remove dirt adhering to the inside of the air filter housing (2), air filter cover (3) and dust discharge valve (7). <i>Note:</i> Vacuum out or wipe out the air filter housing. Do not blow out, as dust and dirt may enter the intake opening of the engine!
4	Insert a new filter cartridge into the air filter housing and apply light pressure to position it in the direction of the sealing surface (6). The frame (5) on the filter cartridge engages in the sealing surface (6).
6	Carefully mount the air filter cover on the air filter housing and lock using 4 holding clamps.

10.2.14 Changing the coolant

This section contains the following subsections:

- **Draining the cooling system**
- **Rinsing the cooling system**
- **Filling the cooling system**

Safety notes

	CAUTION
 	<p>Danger of burns.</p> <p>There is a danger of burns when working on a hot cooling system. The cooling system is pressurized when the engine is hot.</p> <ul style="list-style-type: none"> ▪ Let the engine cool. ▪ Wear safety gloves.
	CAUTION
	<p>Danger of environmental damage from spilled coolant.</p> <p>Coolant is water-polluting.</p> <ul style="list-style-type: none"> ▪ Do not allow them to enter the ground water, water bodies, or sewage system. ▪ Collect the coolant and dispose of it according to local environmental regulations.

Overview

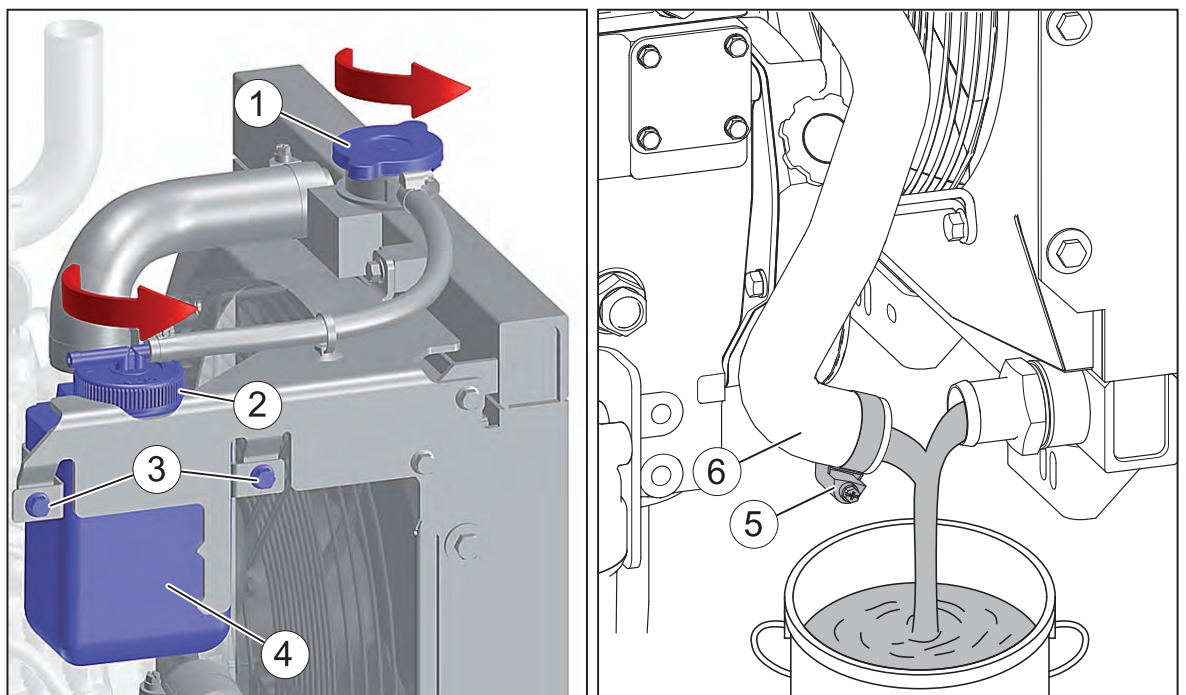

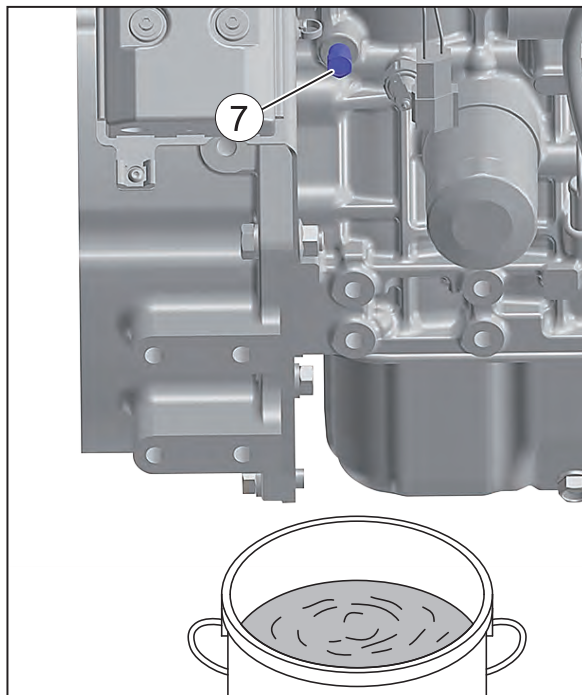

1	Cooler cap
2	Screw plug on the overflow container
3	Fastening screws for overflow container
4	Overflow container
5	Hose clamp
6	Cooler hose
7	Drain screw on engine block

Draining the cooling system

Step	Activity
1	Provide a container to collect the used coolant. The container must be large enough to hold the entire amount of oil. For the amount of coolant, see section 4.1 <i>Engine information and filling quantities</i> , page 16.
2	Screw the cooler cap (1) to the left to the point where it engages and release the pressure.
3	Continue turning the cap to the left and remove it.
4	Loosen the hose clamp (5).
5	Pull off the cooler hose (6) and drain the coolant into the container.
6	Release the screw plug (2).
7	Unscrew the fastening screws (3) and remove and drain the overflow container (4) with retaining bracket.
7	Mount the overflow container again.
8	Unscrew the drain plug (7) from the engine block and drain the coolant into the container.
9	Tighten the drain screw again.
10	Mount the cooler hose (6) on the cooler and secure it with the hose clamp (5).

Rinsing the cooling system

The cooling system only needs to be rinsed if contaminants are detected in the coolant.

Contaminants can include:

- Engine oil due to a defective cylinder head gasket (discoloration of the coolant).
- Corrosion due to used or unsuitable coolant (discoloration of the coolant).
- Foreign bodies due to:
 - Insufficient cleaning during repairs to the cooling system
 - Reuse of drained coolant

As contaminants in the coolant could be an indication of a larger problem, we recommend having the rinsing of the cooling system carried out by trained specialist personnel.

Filling the cooling system

See section *8.3 Filling the cooling system*, page 69

11 Faults

11.1 Troubleshooting

General troubleshooting notes

If the cases listed below have been worked through but the fault continues to persist, please contact your nearest **Hatz service**.

The starter does not turn or only turns slowly. Engine does not start.

Possible causes	Remedy	Section
Battery is defective and/or not loaded.	Check the battery and contact the service center if necessary.	
	Check the belt tension.	
	Check the alternator.	
Battery and/or other cable connections are incorrectly connected.	Check the cable connection between the battery, starter and starter switch.	
Cable connections are loose and/or oxidized.		
Defective starter or starter relay.	Contact HATZ Service.	

At low temperatures (engine does not start).

Possible causes	Remedy	Section
Oil is too viscous and causes a too low starter speed.	Change the engine oil and oil filter. Add engine oil with a suitable viscosity class.	<i>10.2.5 Change the engine oil and oil filter, page 86</i>
Machine is not uncoupled.	If possible, separate the engine from the machine by uncoupling it.	

The engine does not start or does not start immediately, but can be turned with the starter.

Possible causes	Remedy	Section
Hydraulic load too high (especially with multiple hydraulic pumps).	Reduce the hydraulic load – if possible.	
Insufficient compression.	Contact HATZ service.	
Cylinder and/or piston ring wear.	Contact HATZ service.	
Wrong fuel	Only refill with fuel approved by Hatz.	<i>4.5 Fuel, page 19</i>
Fuel supply is interrupted:		
The tank ran out of fuel during operation.	Add fuel.	<i>9.6 Refueling, page 78</i>
Electrical fuel pump is not working.	Check the cabling.	
Fuel prefilter is clogged.	Change the fuel prefilter.	<i>10.2.11 Changing the fuel prefilter, page 95</i>
Main fuel filter is clogged.	Change the main fuel filter.	<i>10.2.12 Changing the main fuel filter, page 97</i>

Engine switches off spontaneously during operation.

Possible causes	Remedy	Section
The tank ran out of fuel during operation.	Fill with fuel.	9.6 Refueling, page 78
Fuel prefilter or main fuel filter is clogged.	Change the fuel filter.	10.2.11 Changing the fuel prefilter, page 95 10.2.12 Changing the main fuel filter, page 97
Electrical defects.	Check the wiring or contact Hatz service.	
Mechanical defects.	Contact HATZ Service.	

The engine loses power and speed.

Possible causes	Remedy	Section
The tank ran out of fuel during operation.	Add fuel.	9.6 Refueling, page 78
Fuel prefilter or main fuel filter is clogged.	Change the fuel filter.	10.2.11 Changing the fuel prefilter, page 95 10.2.12 Changing the main fuel filter, page 97
Inadequate tank venting.	Ensure that the tank is sufficiently vented.	
Line connections are not leak tight.	Check the line screw connections for leak tightness.	

The engine loses power and speed, and black smoke emerges from the exhaust.



Possible causes	Remedy	Section
Dirty air filter unit.	Check the degree of contamination of the air filter and replace if necessary.	10.2.13 Air filter maintenance, page 99
Tappet clearance not OK.	Adjust the tappet clearance.	
Injection nozzle not OK.	Contact HATZ Service.	

Engine becomes very hot. The coolant temperature display lights up.

Possible causes	Remedy	Section
Contamination in the entire area of the cooling air guides.	Clean the cooling air area.	
Cooler fins dirty, or cooler blocked.	Clean the cooler fins, ensure air flow through cooler is not hindered.	10.2.6 Cleaning the radiator fins, page 89 10.2.4 Checking the cooling system, page 83
Thermostat or water pump defective.	Contact HATZ service.	
Coolant level too low.	Check the cooling system.	10.2.4 Checking the cooling system, page 83

12 Storing the machine

Safety notes

 DANGER	
	<p>Danger to life from inhaling exhaust gases.</p> <p>Toxic engine exhaust gases can lead to loss of consciousness, and even death, in closed-off and poorly ventilated rooms.</p> <ul style="list-style-type: none"> ▪ Never operate the machine in closed-off or poorly ventilated rooms. ▪ Do not breathe in the exhaust gases.
 DANGER	
 	<p>Fire hazard from fuel.</p> <p>Leaked or spilled fuel can ignite on hot engine parts and cause serious burn injuries.</p> <ul style="list-style-type: none"> ▪ Only refuel when the engine is switched off and has cooled down. ▪ Never refuel in the vicinity of open flames or sparks that can cause ignition. ▪ Do not smoke. ▪ Do not spill fuel.
 CAUTION	
	<p>Danger of environmental damage from spilled fuel.</p> <p>Do not overfill the fuel tank and do not spill fuel.</p> <ul style="list-style-type: none"> ▪ Collect any leaking fuel and dispose of it according to local environmental regulations.
 CAUTION	
 	<p>Danger of burns.</p> <p>There is a danger of burns when working on a hot cooling system. The cooling system is pressurized when the engine is hot.</p> <ul style="list-style-type: none"> ▪ Let the engine cool. ▪ Wear safety gloves.
NOTICE	
	<p>Comply with the safety chapter!</p> <p>Follow the basic safety instructions in chapter 3 <i>Safety</i>, page 7.</p>

Storing the machine for a lengthy period

Take the following measures if you intend to take the machine out of service for a lengthy period (3-12 months):

Step	Activity
1	Drain the fuel tank until it is nearly empty and fill with FAME*-free fuel. Operate the engine for a few minutes so that only FAME-free fuel is still in the fuel system.
2	Change the engine oil and oil filter (see chapter 10.2.5 <i>Change the engine oil and oil filter</i> , page 86).
3	Replace the fuel prefilter and the main fuel filter (see section 10.2.11 <i>Changing the fuel prefilter</i> , page 95 and 10.2.12 <i>Changing the main fuel filter</i> , page 97).
4	Let the machine cool down.

Step	Activity
5	Check the coolant level and concentration. Refill coolant if necessary (see section <i>10.2.4 Checking the cooling system, page 83</i>). If the concentration is too low, replace the coolant (see section <i>10.2.14 Changing the coolant, page 102</i>).
6	Remove the battery in accordance with the Operator's Manual for the machine and store at ambient temperature. Comply with the local regulations as well as the regulations of the battery manufacturer for the storage of batteries.
7	Close and seal all engine openings (air intake openings, air outlet openings and the exhaust gas opening) so that no foreign bodies can enter, but a small amount of air can still be exchanged. This avoids condensation.
8	After the machine has cooled down, cover it to protect it against contamination, and store it in a dry and clean place.

*FAME = Fatty Acid Methyl Ester

Ambient conditions during storage

- Max. permissible storage temperature: -25 °C to +60 °C
- Max. permissible humidity: 70%
- Protect the engine from direct sunlight

Recommissioning

Step	Activity
1	Remove all covers.
2	Check the cables, hoses and lines for cracks and leak tightness.
3	Check the engine oil level.
4	Check the coolant level.
5	Install the battery in accordance with the Operator's Manual for the machine.

The brand new engine can normally be stored for up to 12 months. The protection lasts up to approx. 6 months at very high humidity and in sea air.

For storage periods of more than 12 months, please contact the nearest **HATZ Service**.

13 Change history

Rev.	Section	Change/additions
03	7.2.3 Rigid engine suspension	Graphic changed.
	7.2.2 Vibration damper	Table no. 9, 506 678 00, mounting foot with break-away: ▪ Height (h) changed to 30/31 mm
	7.4.4 Fuel tank	Note: Check valve (fuel return variants to tank)
	7.9.1 Cold start capability	Correction to -15 °C
	7.10 Maintenance	Accessibility of service points added
	7.5.1 Dimensioning of the exhaust gas system	Outside Ø corrected to 38 mm
		Alignment of muffler outlet pipe

Motorenfabrik Hatz GmbH & Co. KG

Ernst-Hatz-Str. 16
94099 Ruhstorf a. d. Rott
Deutschland
Tel. +49 8531 319-0
Fax. +49 8531 319-418
marketing@hatz.com
www.hatz.com



**CREATING
POWER
SOLUTIONS**

06.2025
Printed in Germany
EN